

7 Channel 2.4 GHz Aircraft Computer Radio System

FLASH7



FLASH

7 Channel 2.4 GHz Aircraft Computer Radio System

OPERATION MANUAL ver. 1.0

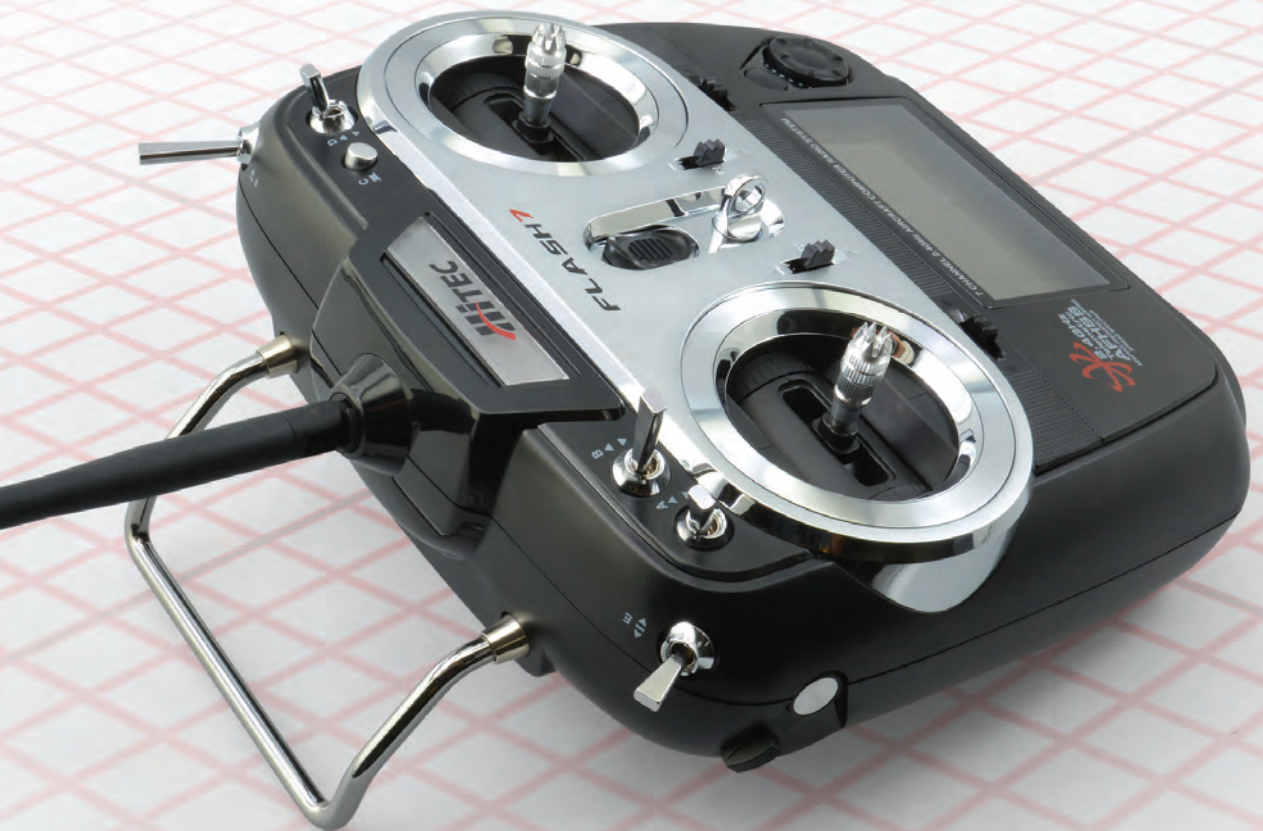

DUAL
PROCESSOR
FAST RESPONSE

SCT
SECURE LINK TECHNOLOGY

4096
RESOLUTION

Before Using

Before using your transmitter, it is recommended that you read this manual in its entirety to become familiar with the product and its features. Failure to operate this product properly can result in damage to property and or cause serious injury.

Important Notices

Please note that Hitec reserves the right to make production changes during the life of our product lines that may impact the information in this manual. For the most up-to-date information on this and any other Hitec product, visit our web site at www.hitecrd.com.



Warning

This product was designed and intended for use with hobby models designed specifically for radio control only. Hitec RCD disclaims all liability for any damages or injuries resulting from the use of this product for anything other than its intended purpose.



Warning

This radio control transmitter is not intended for use by children under 14 years of age. Adult supervision is required for any user under the age of 14.



DISPOSAL OF eWASTE

This symbol indicates that when this type of electronic device reaches the end of its service life, it cannot be disposed of with normal household waste and must be recycled. To find a recycling center near you, refer to the internet or your local phone directory for electronic waste recycling centers.

STATE OF CALIFORNIA PROPOSITION 65 WARNING:

This product contains chemicals known to the State of California to cause cancer. Use caution when handling this product and avoid exposure to any electronic components or internal assemblies.

Regulatory information

Hitec RCD Inc.

Radio Control Hobby Model Controller

Model Name: Flash 7

Operating Frequency: 2.4GHz

Power

Charger: None

Transmitter: 6.0V (4AA Alkaline Batteries)

This device complies with part 15 of the FCC Rules. Operation is subject to the following two conditions:

1. This device may not cause harmful interference.
2. This device must accept any interference received, including interference that may cause undesired operation.

Table of Contents

SECTION 1

Introduction

Safety Information.....	6
Product Support.....	7
Steps for Successfully Programming the Flash 7 Radio.....	8
System Component Specifications.....	9
Terms and Icons.....	10
Powering the Flash 7.....	11
Transmitter Controls.....	11
Main Menu.....	12
Transmitter Warnings.....	12
Maxima Series Receivers.....	13
Optima and Minima Receivers.....	15
Fail Safe and Hold Mode Setup.....	19
Telemetry System.....	20
Range Check Function.....	21
Scan Mode Function.....	22
SLT System.....	23

SECTION 2

Quick Start Guides

Airplane Quick Start Guide.....	24
Helicopter Quick Start Guide.....	26

SECTION 3

System Menu Programming

System Menu.....	28
Model Select Menu.....	29
Model Type Menu	32
Model Type ACRO Menu Programming.....	32
Model Type GLID Menu Programming.....	33
Model Type HELI Menu Programming.....	35
Channel Selection Menu.....	36
Trim Step.....	37
Trainer Function.....	37
Control Modes.....	40
Management Menu.....	40

Table of Contents**SECTION 4****Common Model Programming Menu**

Working with the Common Model Function Menus.....	43
Servo Reverse.....	44
Sub Trims.....	44
Dual Rates and Exponentials.....	45
Switch Assignment.....	47
End Point Adjustments	47
Servo Speed	48
Programmable Mixes	48
Timers.....	51
Servo Monitors.....	54
Throttle Lock.....	55

SECTION 5**ACRO and Glider Programming**

Acro and Glider Programming Menu.....	56
Flight Conditions.....	57
Aileron Differentials.....	58
Elevon Mixing.....	59
V-Tail Mixing.....	60
Ailevator Mixing.....	62
Aileron to Rudder Mixing.....	63
Elevator to Camber Mixing.....	65
Camber Mixing (GLID Only).....	68
Flap Control.....	70
Offset.....	71
Butterfly Mixing (GLID Only).....	72
Gyro.....	75
Throttle Cut (ACRO Only).....	76
Throttle Curve.....	78

Table of Contents**SECTION 6****Helicopter Programming**

Helicopter Programming Menu.....	80
Flight Conditions.....	80
Throttle Cut.....	82
Throttle Hold.....	83
Gyro.....	84
Revolution Mixing.....	86
Swash to Throttle Mixing.....	88
Swash Mixing.....	90
Throttle Curve.....	91
Pitch Curve.....	93
Swash Ring.....	95

SECTION 7**Using the Telemetry System**

Working with the Sensor Menu.....	96
GPS.....	96
RPM.....	97
Temperature.....	98
Battery.....	98
Servo Manager.....	99
Advanced Telemetry Sensors.....	99
Viewing Telemetry Data.....	100

APPENDIX A**Hardware Adjustments**

Stick Length Adjustments.....	101
Stick Lever Tension Adjustment / Mode Change.....	101

Introduction

Thank you for purchasing the Flash 7 radio by Hitec. Designed for all popular aircraft types, the Flash 7 delivers lightning fast response with its 7ms frame rate and 4096 step resolution. You can trust Hitec's bi-directional, AFHSS (Advanced Frequency Hopping Spread Spectrum) 2.4GHz technology to guide your sailplane, gas, glow or electric power plane or heli to a safe landing every flight. We are sure you will find the Flash 7 one of the easiest radios to program. Please review this entire manual to learn how to safely use your new radio. It's a good idea to keep the manual with your Flash 7 at all times.

Features

1. **Triple Protocol 2.4GHz Transmitter:** The Flash 7 can transmit using three different 2.4GHz signals.
 - a. Our original AFHSS bi-directional telemetric 2.4Ghz signal used with the Minima and Optima series receivers.
 - b. Our Low Latency G2 AFHSS 2.4GHz signal used with Maxima series receivers.
 - c. The SLT™ protocol found in many Tx-Ready aircraft. For more info visit www.Tx-Ready.com.
2. **3 in 1 Radio:** With advanced Acro, Glider and Helicopter programming you have the ability to advance your flying skills without having to upgrade your radio.
3. **Precise 4096 Resolution:** At two to four times the resolution of most transmitters, the Flash 7's 4096 step resolution gives you more precise and crisp servo movement.
4. **Backlit Graphical LCD screen:** Makes it easy to see the programming and telemetry displays.
5. **Push Button / Jog Dial Programming Interface:** So that programming the Flash 7 is a breeze.
6. **2 Virtual Master Channels for Mixing:** Allows for advanced mixing found only in radios with more channels.
7. **6 Assignable Switches and 2 Sliders:** Gives you plenty of choices for total control.
8. **Telemetry Capabilities with our Optima Receiver:** Keeps you informed of what's going on in your plane.
9. **DCS Port (Battery Voltage Power Out):** Powers optional accessories such as VR goggles or head tracking units.

Safety Information

Flying models can be dangerous if proper safety precautions are not followed. Here are a few critical safety suggestions to keep you and others safe.

Are you experienced?

Flying models is not an intuitive process. Most accomplished model pilots were taught by another modeler. We encourage you to seek help during your early flight experiences and if required, during the building and radio gear installation process. Unlike some other hobbies, model airplane flying has evolved into a social event. There are approximately 2,500 model aircraft clubs in America. Friendship and help could be right around the corner. Ask your local hobby shop about clubs in your area.

Where to Fly

Having enough land for your own model airport is rare. Most of us fly at club administrated model fields. The local ball field can be tempting but rarely has the space needed and your liability is high should you damage property or hurt an innocent bystander. We recommend you fly at a sanctioned model aircraft field.

Join the AMA

In America, the Academy of Model Aeronautics (AMA) is an organization of model enthusiasts that provides resources and insurance to modelers. The AMA also lobbies the Government concerning legislation that impacts modelers. Visit their web site for more information at www.modelaircraft.org.

Academy of Model Aeronautics
5151 East Memorial Drive
Muncie, Indiana 47302
Toll Free: 800 435-9262

Fundamental Guidelines for Safe Flying

1. Model aircraft can be dangerous when operated or maintained improperly.
2. DO NOT fly over people or personal property.
3. DO NOT fly in adverse weather conditions or high winds.
4. The equipment we use in the R/C hobby is sensitive electronic gear. Have receivers checked after a crash before using them in another aircraft.
5. DO NOT fly under the influence of alcohol or drugs or if you are feeling ill.
6. DO NOT fly near power lines or transmission towers.
7. If available use the Fail-Safe function to lower the throttle in case of a signal "lock-out."
8. DO NOT fly alone.

Safety Information Regarding Your Radio System

1. Make sure you do a range check before flying. If it does not range check satisfactorily, DO NOT fly.
2. Know the condition of your batteries. Make sure they are sufficiently charged.
3. Make sure all control surfaces respond correctly to the input from the transmitter.
4. Be sure that the throttle is off when turning on your airplane.
5. Always turn your transmitter on first and turn it off last.
6. If the controls don't respond properly during flight, land immediately.

Product Support

Flash 7 Programming Support

While every attempt was made by the Flash 7's developers to make the software interface easy and logical, most users will require programming help at some point. There are several "get help" options available to you.

Hitec Customer Service

Help is available from the Hitec office through phone support and e-mail inquiries. The U.S. office is generally open Monday thru Friday, AM 8:00 to PM 4:30 PST. These hours and days may vary by season. Every attempt is made to answer every incoming service call, but should you get voice mail, leave your name and number and a staff member will return your call.

Hitec Web Site

Make plans to visit the Hitec web site on a regular basis at www.hitecrd.com. There you will find specs and other information about the entire Hitec product line, and soon our FAQ pages will hold valuable information about the Flash 7.

The On-Line Community

One of the benefits of the extensive R/C online community is the vast wealth of archived knowledge available. Hitec sponsors forums on most of the popular R/C web sites where a Hitec staff member or representative answers all manner of product related questions. Bringing together strangers with common interests is proving to be one of the greatest gifts of the internet. If past history is any guide to the future, we are certain forums will be started about the Flash 7.

Warranty and Non-Warranty Service

All Hitec products carry a two year from date-of-purchase warranty against manufacturer's defects. Our trained and professional service representative will determine if the item will be repaired or replaced. To provide all the necessary information we need to administer your repair, visit our web site at www.hitecrd.com to download the repair form. Complete the form and send in your item for repair.

Hitec Service
12115 Paine St.
Poway CA 92064
(858)748-6948
service@hitecrd.com

Steps for Successfully Programming the Flash 7 Radio

Using this Manual

This manual is a valuable resource detailing the programming and operation methods of the Flash 7 radio. The Flash 7 manual is divided into seven distinct sections:

1. Introductory material that is mandatory reading. This is where you will learn detailed information that will be invaluable to the successful programming of the Flash 7.
2. Quick Start Guides.
3. System Menus.
4. Model Function Menus.
5. ACRO And Glider Programming Menu.
6. HELI Programming Menu.
7. Telemetry Function.

Warning, Caution, Note and Tip Boxes

Throughout the manual, you will see important information inside a labeled box. Take note of this important information.



Warning



Caution



Tip



Note

Warning: This icon alerts you to warnings that relate to your safety and help you avoid causing damage to your equipment.

Caution: This icon indicates that careful attention must be paid.

Tip: This icon points out valuable technical information.

Note: This icon indicates that further information is available.

User Interface

User Interface

The Flash 7 utilizes a jog dial/push button and a back button to access the various functions and input settings in the radio. The jog dial/push button is used to scroll through screens and programming features. Press the jog dial to enter a menu, activate or confirm a setting. Pressing the back button takes you to the previous screen or function. Pressing both the jog dial and back buttons takes you to the System Menu where most of the initial aircraft setup takes place.

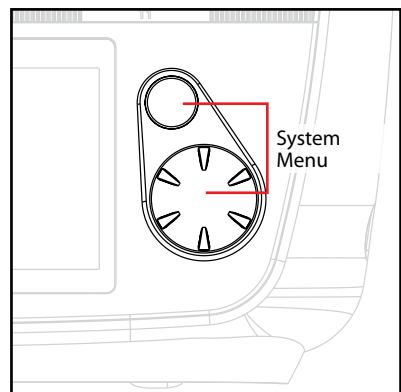
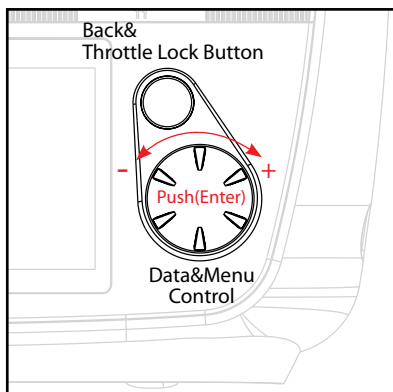

Quick Start Guides

Quick Start Guides

We recommend that you read the introductory information in section one, then proceed to one of the quick start guides and start programming. After following along with the quick start guide you will have a feel for the way the Flash 7 programming is laid out. We encourage you to set up a few aircraft before you fly the Flash 7. It will be time well spent and help acquaint you with the programming process.

System Component Specifications

Flash 7 Transmitter

Modulation: 2.4GHz

Optima (AFHSS Bidirectional): For use with the Optima series telemetry capable receivers.

Minima (AFHSS Single-direction): For use with the Minima series receivers.

Maxima (AFHSS Single-direction): For use with the High response low latency Maxima series receivers.

Power Supply: 4AA Alkaline Batteries or Optional 4.8-7.2v NiMh or Life, Li-Ion or LiPo Battery

Current Drain: 300 mA

Available Receivers

Optima Series 2.4GHz Receivers

Model	Size	Weight	Stock Number
Optima 6 Lite	1.76 x 1.11 x 0.29in (44.9 x 18.4 x 7.40mm)	0.33oz (9.4g)	29438
Optima 6	1.81 x 0.82 x 0.47in (46.1 x 21.3 x 12.1mm)	0.52oz (15g)	28410
Optima 7	2.20 x 0.79 x 0.43in (56.9 x 20.8 x 11.6mm)	0.60oz (17g)	28414
Optima 9	1.85 x 1.14 x 0.59in (47.7 x 29.1 x 15.5mm)	0.77oz (22g)	28425

Operating Voltage: 3.7~8.4V from a receiver battery or BEC circuit from an Electronic Speed Control
4.8~35v Using SPC Function

Current Drain: 30mA

Maxima Series 2.4GHz Receivers

Model	Size	Weight	Stock Number
Maxima 6	1.29 x 0.81 x 0.42in (33 x 20.8 x 10.7mm)	0.22oz (6.4g)	27524
Maxima 9	1.45 x 0.97 x 0.57in (37 x 24.4 x 14.6mm)	0.28oz (8.1g)	27525

Operating Voltage: 3.7~8.4V from a receiver battery or BEC circuit from an Electronic Speed Control

Current Drain: 30mA

Minima Series 2.4GHz Receivers

Model	Size	Weight	Stock Number
Minima 6 T	1.19 x 0.81 x 0.27in (30.4 x 20.8 x 7.1mm)	0.22oz (6.5g)	26610
Minima 6 E	1.24 x 0.81 x 0.42in (31.7 x 20.8 x 10.9mm)	0.28oz (8.1g)	26612
Minima 6 Lite	1.22 x 0.77 x 0.33in (31.2 x 19.5 x 8.5mm)	0.14oz (4g)	26614
Minima 6S	1.19 x 0.81 x 0.27in (30.4 x 20.8 x 7.1mm)	0.19oz (5.4g)	26615

Operating Voltage: 3.7~8.4V from a receiver battery or BEC circuit from an Electronic Speed Control

Current Drain: 30mA

Terms and Icons

Glossary of Terms

AFHSS 2.4GHz Signal: Hitec's 2.4GHz R/C signal protocol. Adaptive Frequency Hopping Spread Spectrum.

Telemetry: Data signal from the model, transmitted to the transmitter.

Range Check: A ground check of the signal strength between the transmitter and receiver done before flying.

Link (ID Setting): Link or "binding" a 2.4GHz receiver to its master transmitter.

HPP-22 PC Interface: PC interface accessory for storing model memories and updating firmware.

Icon Identification

MODEL: The model menu contains the model programming for the active model.

ACRO: Menu for fixed wing, glow, gas and some electric models.

GLID: Menu for gliders and some electric models.

HELI: Menu for rotary wing aircraft.

AILE: Aileron for fixed wing menus and the "roll" swash input for helis.

ELEV: Elevator for fixed wing menus and the "pitch" swash input for helis.

RUDD: Rudder for fixed wing menus and the "yaw", or tail rotor input for helis.

INH: Inhibit is used to "turn off" a function.

ACT: Active, "turns on" a function.

NULL: "No switch" selected, the function or feature will be "on" all the time.

AUX: An "open" channel, without a control assigned to it.

J1: Right gimbal, up and down control.

J2: Right gimbal, side to side control

J3: Left gimbal, up and down control.

J4: Left gimbal side to side control.

T1: J1 control trim.

T2: J2 control trim.

T3: J3 control trim.

T4: J4 control trim.

RS: Right slider control.

LS: Left slider control.

Powering the Flash 7

The Flash 7 includes a 4 x AA battery tray for use with either Alkaline or rechargeable AA size batteries. The Flash 7 is capable of operating on 4.8 – 8.4 volts DC. This wide range voltage flexibility allows you to use either 4 NiMh cells or a 2 cell LiPo, LiFe or Li-Ion battery pack.



Make sure you use a charger suitable for the battery pack you are using. It is recommended that you remove the battery from the transmitter when charging it.

Selecting the Battery Type

The Flash 7's default battery type is Alkaline which has a warning threshold of 4.0 volts. If you choose to use a different type of battery you must select the battery type in the System Management menu.

The preset warning thresholds for each type are

- Alkaline 4.0 Volts
- NiMh or NiCd 4.3 Volts
- LiPo 7.0 Volts
- LiFe 6.0 Volts

Power Meter

On the home screen of the Flash 7 you can visually see the voltage reading as well as a bar indicating the amount of power left in the battery.

Transmitter Controls

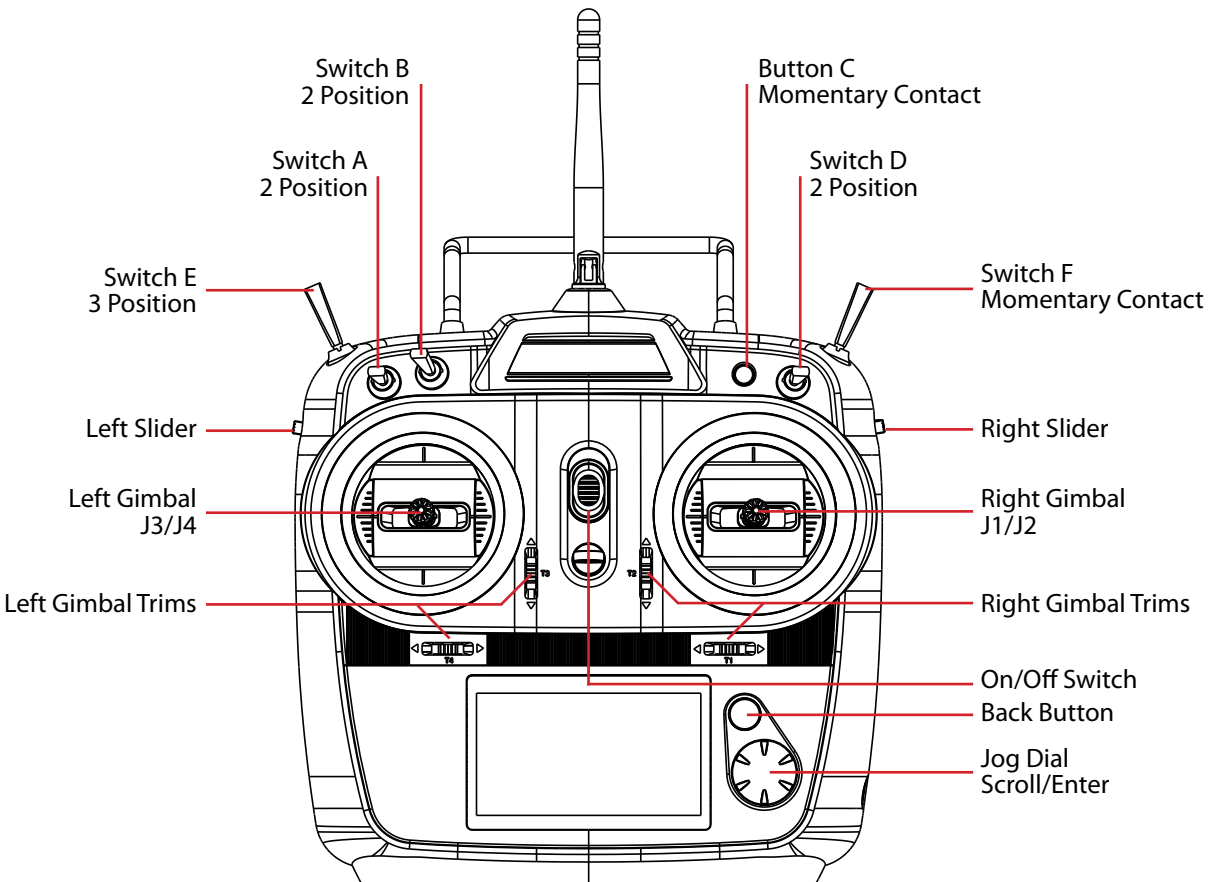

Main Menu

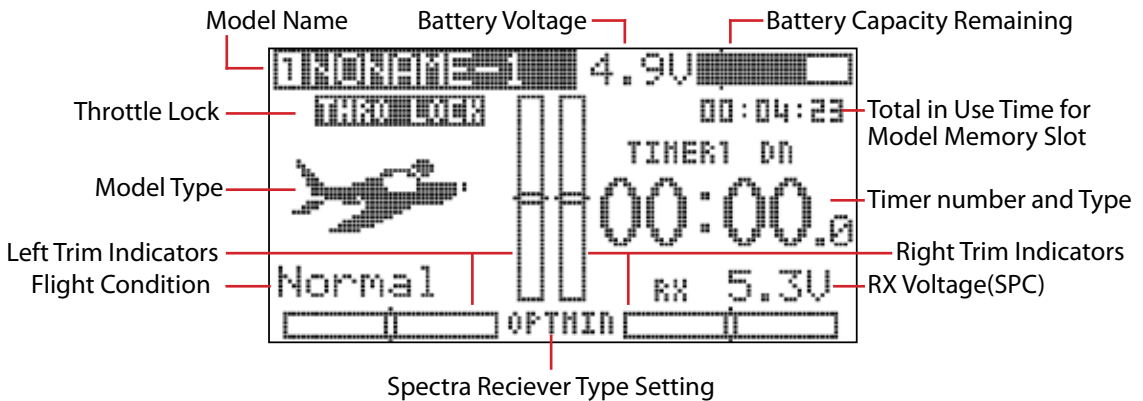

From the main menu, you can quickly access certain settings by scrolling to them and pressing the jog dial.

The following items have the quick access feature:

Model Name to access the Model Select menu.

Spectra Receiver Type to access the Spectra menu.

Time to access the Timers menu.

Transmitter Warnings

The Flash 7 has a few warning alarms that you should be aware of.

Start Up Warnings

High Throttle

If the throttle is positioned above idle during the system "boot-up to transmit" process, a warning beep will occur and the following warning screen will be displayed.

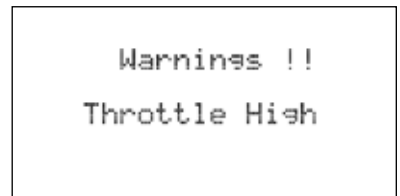

Condition on Warning

If you have flight conditions and other mixing programmed for the active model and they are switched "on" during the "boot-up to transmit" process, a warning sound will occur and the following warning screen will be displayed.

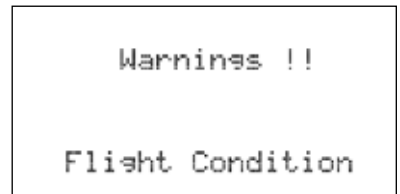

In Flight Warnings

If the transmitter should start a continuous beeping during flight, land immediately and evaluate the cause of the warning. There are two warnings that may occur in flight.

Low Transmitter Battery Warning

When the transmitter battery power falls to a critically low level, a warning sound will occur.

Low Aircraft Battery Warning

When using the Optima series of receivers and the on-board battery or the battery connected to the SPC port is critically low, your transmitter will start beeping warning you that you should land immediately. This feature does not occur when using single direction receivers such as the Maxima and Minima series of receivers.

Maxima Series Receivers



The Maxima series is designed for use with G2 AFHSS radios such as the Aurora 9X and Flash series. USE ONLY Digital SERVOS with the Maxima receivers. Analog servos cannot be used with the Maxima series receivers.

MAXIMA 6

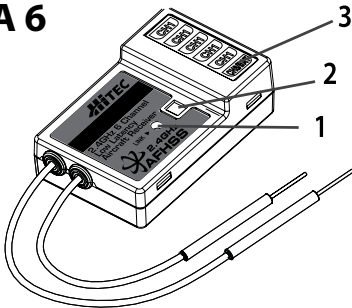

MAXIMA 9

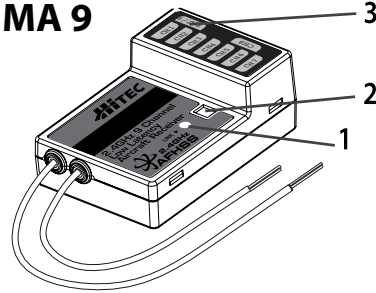

1. **Function Button:** Used for binding the receiver to the Flash 7 and entering the FAIL-SAFE or Hold feature.
2. **Dual LED Status Indicator:** Indicates the set-up process codes and current status of the receiver.
3. **Channel Output and Battery Input Ports:** The ports for battery power input and servos, gyros and other accessories' output ports are located at the side end of the Maxima receivers.
4. **Low Battery Warning:** If the receiver's battery levels fall below 3.6V, the RED LED will flash.
5. **FAIL-SAFE/Hold Mode Selectable:** Servos and other accessories position can be set with a FAIL-SAFE point if power to the receiver is lost.

Maxima Series Receiver Antenna Installation

The Maxima receiver series antenna system was created to provide the optimum signal capture capability. Our two antennas must be installed properly. Refer to the illustration below.

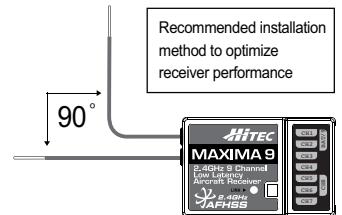
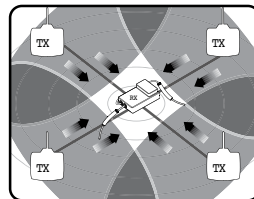

Maxima Series Receiver Connection Diagrams

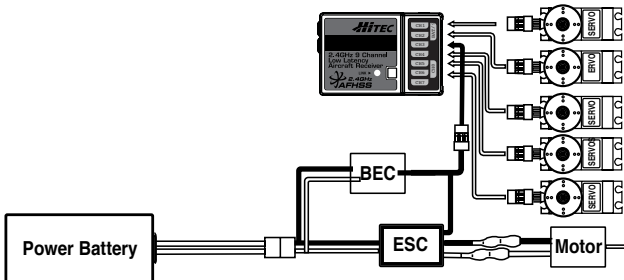

Electric powered aircraft with Electronic Speed Control Use this method on electric planes using ESCs providing power to the receiver and servo functions.

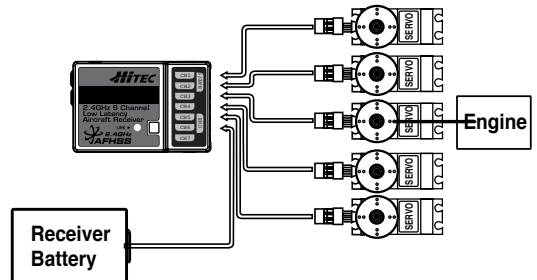



Glow, gas or electric powered aircraft using a separate receiver battery supply. Follow this connection diagram when using a regulated Li-Po, or 4.8 to 6V receiver battery.

Maxima Series Receiver Connection Diagrams

Your Hitec AFHSS system uses a communication protocol that links and binds the Hitec 2.4GHz receiver to your transmitter. Once the receiver and transmitter are “bound”, no other transmitter can interfere with your receiver during its operation. In the case of multiple model memory transmitters, you can bind as many Hitec 2.4GHz receivers to your transmitter, one per model memory, as necessary. Each transmitter and receiver set is paired at the factory for your convenience.

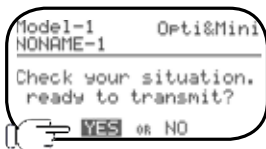
- 1** Turn on the transmitter and select “yes” to the “Ready to Transmit” prompt by pressing the jog dial.





- 2** Press the jog dial and back button simultaneously to enter the System Menu list. From here scroll to the SPECTRA function and press the jog dial to enter the Spectra setup menu.

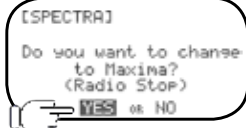

- 3** Press the jog dial to activate the receiver selection and scroll to the “Maxima” receiver.

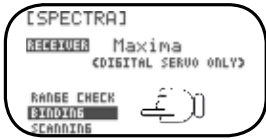

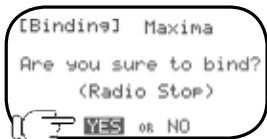
Press the jog dial to save your setting. When prompted to change the receiver type select yes and press the jog dial to confirm your choice.

- 4** Now when prompted if you are “Ready to Transmit” select “Yes” and push the jog dial to confirm your response. Back at the receiver selection screen, scroll to BINDING and press the jog dial to enter the binding screen. Select “yes” if you would like to proceed with the binding process.

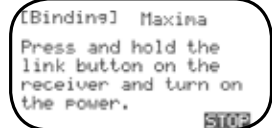
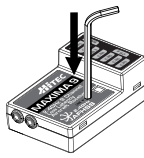
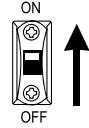

- 5** Press and hold the link button on the Receiver and turn on the power.

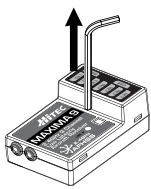

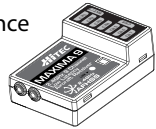
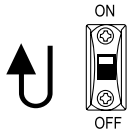

- 6** Release the link button. Both RED and BLUE LEDs will be blinking rapidly to find the transmitter’s signal.

- 7** When the LED stops blinking, press the jog dial to get to the next screen. The blue LED will glow solid.
- 8** Turn the power to the receiver off, then back on. Check for a solid blue LED light. Once it’s on, press the jog dial to FINISH the binding process. Make sure all functions are working properly before flying your model.



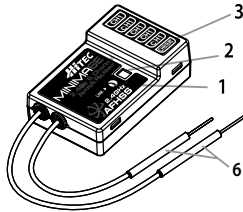

Optima and Minima Series Receivers

The following information contains the complete directions on how to use the Optima and Minima series receivers (version 3.00(0)). We encourage you to review this information before using these products.

**MINIMA 6S & MINIMA 6T**

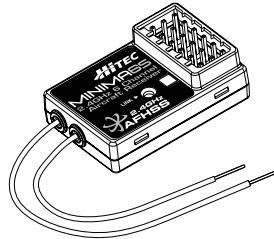
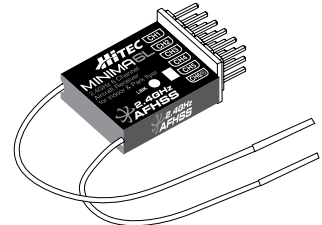
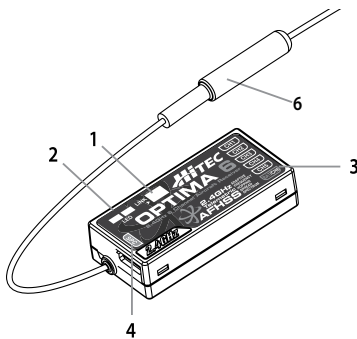
(6T output block is on top)

**MINIMA 6S****MINIMA 6L****OPTIMA 6 & OPTIMA 6 LITE**

(6L utilizes a soft case and exposed output block)

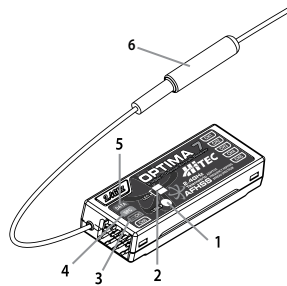
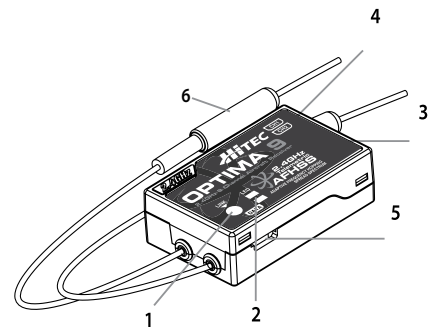
**OPTIMA 7****OPTIMA 9**

1. **Function Button:** Used for binding the receiver to a module or Hitec 2.4 built-in transmitters, entering the FAIL-SAFE or Hold feature.
2. **Dual LED: Status Indicator:** Indicates the set-up process codes and current status of the receiver.
3. **Channel Output and Battery Input Ports:** The ports for battery power input and servos, gyros and other accessories' output ports are located at the side.
4. **SPC (Supplementary Power Connection)*:** Power the Optima and Minima receivers function with up to a 35V. electric aircraft motor battery.
5. **Telemetry Sensor and Data Port*:** A three pin servo plug connector port is featured on the Optima 7 and Optima 9 (Optima 6 is not applicable.) Using the HPP-22 PC interface accessory, this port serves to facilitate upgrading the device's software and interfacing the optional onboard sensor station.
6. **BODA (Boosted Omni Directional Antenna) System*:** Hitec's exclusive 2.4GHz BODA System will show you another way of using our 2.4GHz systems. The single Omni-directional antenna booster makes it much easier to install the 2.4GHz antenna. Intensive tests have proven that the single BODA system in our 6 & 7 channel systems is better than or equal to our competitor's dual antenna systems while our Optima 9 receiver features a dual BODA system to give the added security that larger models need. Installation is easy and simple, insert the antenna into the supported antenna holder and stick it to the desired spot you wish to install.

Optima and Minima Series Receivers cont.

Compatibility:

The OPTIMA & MINIMA receivers are compatible with transmitters using the Hitec AFHSS 2.4 GHz system, such as, Spectra 2.4 module or dedicated built-in module AFHSS 2.4 Hitec transmitters.

FAIL-SAFE/Hold Mode Selectable:

Servos and other accessories can be set with a FAIL-SAFE point if power to the receiver is lost.

Jumper*:

The jumper is installed at the factory and is used when the receiver is powered by an electronic speed control, a commercially available B.E.C. (battery eliminator circuit), dedicated 4.8 to 6V. NiMH battery pack, or regulated Li-Po battery. The jumper is removed when the receiver is powered using the SPC feature.

*These functions/ features are only for OPTIMA series receivers.

Common Receiver Connection Diagrams

Electric powered aircraft with Electronic Speed Control: This configuration is appropriate for electric planes using ESCs providing power to the receiver and servo functions.

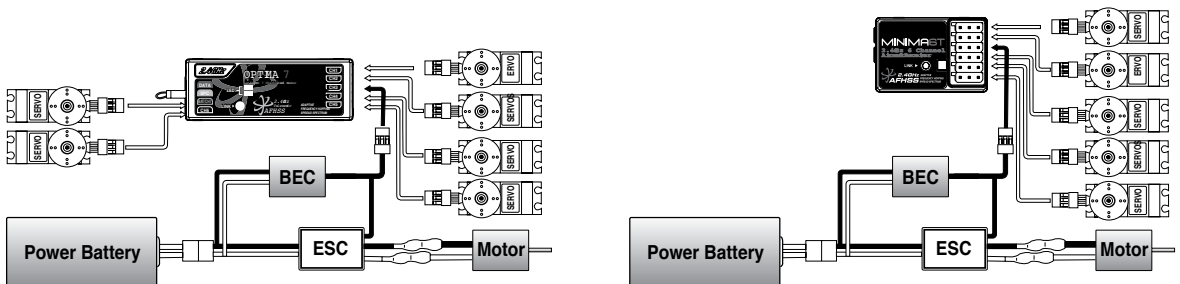

Glow, gas or electric powered aircraft using a separate receiver battery supply: Follow this connection diagram when using a regulated Li-Po, or 4.8 to 6V receiver battery.

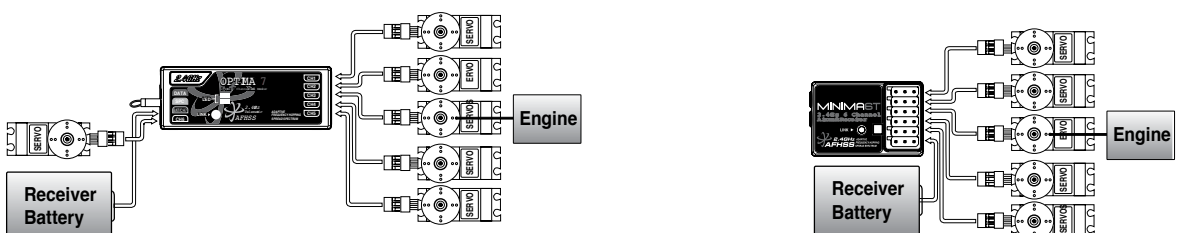

Optima and Minima Series Receiver Link (ID-Setting or Bind)

Your Hitec AFHSS system uses a communication protocol that links and binds the Hitec 2.4GHz receiver to your transmitter. Once the receiver and transmitter are “bound”, no other transmitter can interfere.

<p>1</p>	<p>Turn on the transmitter and select “Yes” to the “Ready to Transmit” prompt by pressing the jog dial.</p>			
<p>2</p>		<p>Press the jog dial and back button simultaneously to enter the System Menu list. From here scroll to the SPECTRA function and press the jog dial to enter the Spectra setup menu.</p>		
<p>3</p>	<p>Press the jog dial to activate the receiver selection and scroll to the “Opti&Mini” receiver.</p>		<p>Press the jog dial to save your setting. When prompted to change the receiver type select “Yes” and press the jog dial to confirm your choice.</p>	
<p>4</p>	<p>Back at the receiver selection screen, scroll to BINDING and press the jog dial to enter the binding screen.</p>		<p>Select the type of receiver you are using, either Optima or Minima, and push the jog dial to confirm your selection.</p>	
<p>5</p>		<p>OPTIMA</p>	<p>MINIMA (MAXIMA)</p>	
<p>Select “Yes” for binding.</p>				
<p>6</p>	<p>Press and hold the link button on the Receiver and turn on the power.</p>			
<p>7</p>	<p>Release the link button.</p>		<p>Release the Link button, both RED and BLUE LEDs will be blinking rapidly to find the transmitter’s signal.</p>	

Optima and Minima Series Receiver Link (ID-Setting or Bind) cont.

8

When the binding process is completed, it automatically goes to the finish screen. (The BLUE and RED LEDs will be solidly on)

```
[Binding] Optima
Reboot RX &
check all function
if correct,
press [Finish].
```

When the LED stops blinking, press the jog dial to get to the next screen. The blue LED will glow solid.

```
[Binding] Minima
Reboot RX &
check all function
if correct,
press [Finish].
```

9

Turn the power to the receiver off, then back on. Check for a solid blue LED light. Once on, press the jog dial to FINISH the binding process. Make sure all functions are working properly before flying your model.

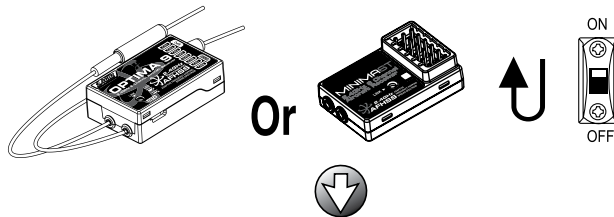

If all functions work well, press the Finish icon on the screen to finish binding.

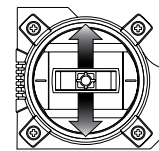

Control Check



Good work



Caution

If any function is not working as described, please go back to step 6 and repeat the binding again.

FAIL-SAFE and Hold Mode Setup

If the FAIL-SAFE function is set up and used properly but the receiver signal is somehow interrupted, the servos will move to your previously stored FAIL-SAFE setup. If you do not activate the FAIL-SAFE function, the signal is switched off after the HOLD period of 1 sec. This means that the servos become “soft” and remain in their last commanded position under no load (this may equate to full-throttle!) until a valid signal is picked up again. In the interest of safety, we recommend that FAIL-SAFE should always be activated, and the FAIL-SAFE settings should be selected so as to bring the model to a non-critical situation (e.g. motor idle / electric motor OFF, control surfaces neutral, airbrakes extended, aero-tow release open, etc.).

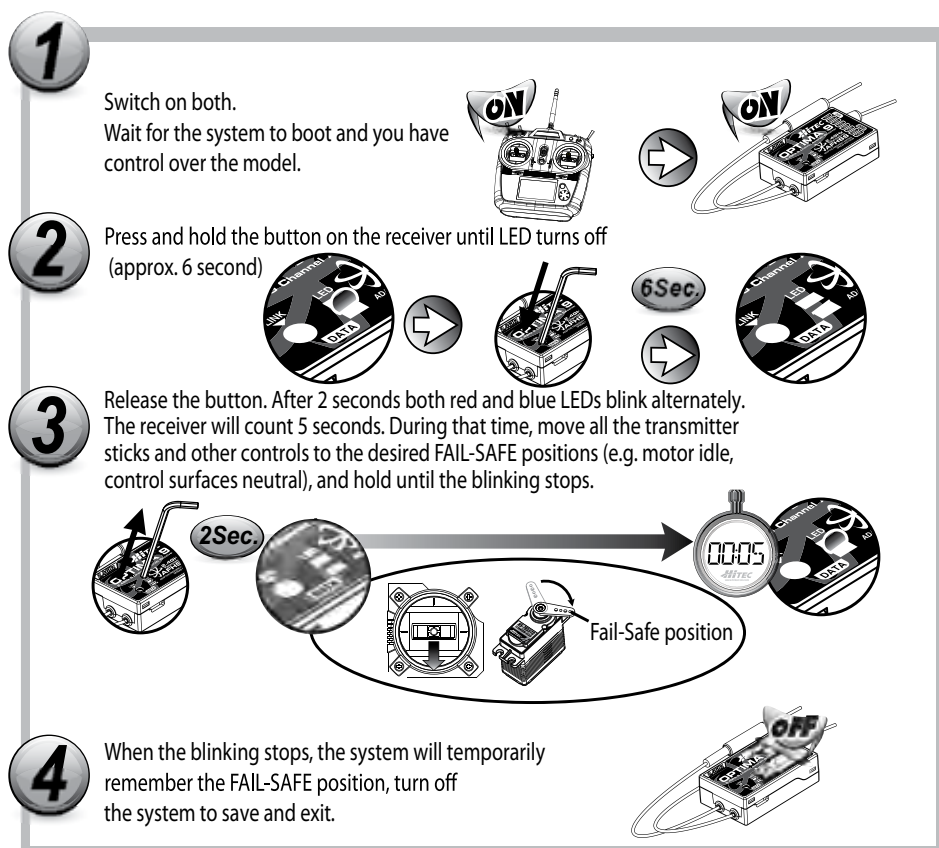

Testing the FAIL-SAFE Setting

Move the sticks to positions other than the FAIL-SAFE settings, and then switch off the transmitter. The servos should now move to the FAIL-SAFE positions previously stored after the one second HOLD period.

How to turn FAIL-SAFE Off and reactivate the Hold Mode

- Switch on the transmitter, then the receiver. Wait for the system to boot and you have control over the model.
- Press and hold the receiver function button for 6 seconds and release it. After 2 seconds, the red and blue LEDs will blink rapidly.
- Immediately press the receiver function button once.
- FAIL-SAFE Mode is now deactivated and HOLD mode is activated.
- Turn the transmitter off, then the receiver off.
- Turn the system back on to use it.

Telemetry System

The Hitec Spectra 2.4 System and Optima Series receivers feature full telemetry capabilities (except Optima 6) and include a Low Receiver Battery Warning as a basic function.

Functions (Available with Optima 7 and 9):

Hitec offers a wide variety of telemetry sensors designed to work with both fuel and electric powered aircraft. Check our website at www.hitecrd.com for the latest available telemetry accessories.



Note

- The telemetry function is applicable for OPTIMA series receivers only.



Warning

- The actual battery voltage level could be different.
- When the 2.4GHz system and High Voltage servos are used together, we strongly recommend using fully charged large capacity battery packs.

Range Check Function

It is critical that before each flight session you perform a range check that confirms the signal between the receiver and transmitter is appropriate. To do a range check, use a power-down mode to reduce the transmitter signal strength. During this power-down mode, you should walk away from the secured aircraft carrying the transmitter to a distance of approx. 30 meters, to test the effective range.

1. Turn on the transmitter and select "Yes" from the "Ready to Transmit" prompt by pressing the jog dial.

```
Model-1      Opti&Mini
NONAME-1

Check your situation.
ready to transmit?

  YES  OR NO
```

2. Press the jog dial and back button simultaneously to enter the System Menu list. From here, scroll to the SPECTRA function and press the jog dial to enter the Spectra setup menu.

```
System.List
MDL SEL      Sensor
MDL Type     Spectra
Channel      Mode
Trim Step    Management
Trainer      INFO
```

3. Scroll to the RANGE CHECK and push the jog dial to enter the range check function.

```
[SPECTRA]
RECEIVER Opti&Mini

[RANGE CHECK]
BINDING
SCANNING
```

4. If you are sure you want to proceed with the range check, select "Yes" and press the jog dial to continue.

```
[Range Check]
Are you sure to check
the radio range?
(Power down)

  YES  OR NO
```

5. Walk away from the secured aircraft carrying the transmitter to a distance of approx. 30 meters, to test the effective range. Once you have completed the range check, push the jog dial to end the range check.

```
[Range Check]
Radio power is down!
(100feet/30m clear)

  STOP
```

Scan Mode

In Scan Mode the transmitter and receiver will scan all available channels every time you turn it on. It will then choose the cleanest frequencies to use. Scan Mode is preferable to use when flying in a crowded 2.4GHz environment.

1. Turn on the transmitter and select "Yes" to the "Ready to Transmit" prompt by pressing the jog dial.

```
Model-1      Opti&Mini  
NONAME-1  
-----  
Check your situation.  
ready to transmit?  
YES OR NO
```

2. Press the jog dial and back button simultaneously to enter the System Menu list. From here scroll to the SPECTRA function and press the jog dial to enter the Spectra setup menu.

```
System.List  
-----  
MDL SEL      Sensor  
MDL Type     Spectra  
Channel      Mode  
Trim Step    Management  
Trainer      INFO
```

3. Scroll to the Scanning selection and push the jog dial to enter the Scanning function.

```
[SPECTRA]  
RECEIVER Opti&Mini  
-----  
RANGE CHECK  
BINDING  
SCANNING
```

4. If you are sure you want to proceed with the Scanning, select "Yes" and press the jog dial to continue.

```
[Scanning]  
Are you sure to scan  
frequency table?  
(Radio Stop)  
YES OR NO
```

5. If Scan Mode link is successful, you will be prompted to reboot the receiver.

```
[Binding] Minima  
Press and hold the  
link button on the  
receiver and turn on  
the power.  
NEXT
```

Scan Mode cont.

6. Check to see that all functions are operating correctly. If they do, press Finish. You now have successfully bound your receiver in scan mode.

```
[Binding] Optima
Reboot RX &
check all function
if correct,
press [Finish].
Finish
```

SLT Technology

In addition to our proprietary AFHSS technology the Flash 7 has the ability to transmit using Secure Link Technology (SLT). This allows you to fly the numerous Tx-Ready models available on the market. For more information visit Tx-Ready.com for models utilizing this technology. Follow these instructions to utilize SLT with your Flash 7.

1. Turn on the transmitter and select "Yes" to the "Ready to Transmit" prompt by pressing the jog dial.

```
Model-1 Opti&Mini
NONAME-1

Check your situation.
ready to transmit?

YES OR NO
```

2. Press the jog dial and back button simultaneously to enter the System Menu list. From here scroll to the SPECTRA function and press the jog dial to enter the Spectra setup menu.

```
System.List
MDL SEL Sensor
MDL Type Spectra
Channel Mode
Trim Step Management
Trainer INFO
```

3. Press the jog dial to activate the receiver selection and scroll to the "SLT" receiver.

```
[SPECTRA]
Do you want to change
to S.L.T. ?
(Radio Stop)
YES OR NO
```

```
[SPECTRA]
RECEIVER S.L.T.
```

SLT Binding

The following procedure is for binding typical SLT receivers to the Aurora 9X. These methods may vary from manufacturer to manufacturer. Check your receiver manual for any variances to these instructions.

1. Turn on the Flash transmitter and when prompted to transmit choose "YES."
2. Apply power to the Receiver.
3. If the receiver LED flashes once and then stays on, the receiver is already linked to the transmitter and you can skip to the next section. Otherwise, insert a small diameter screwdriver into the hole marked "LINK" or "BIND" on the receiver and press the button until the LED on the receiver glows red and then turns off after about one second.
4. Release the "LINK" or "BIND" button.

Airplane Quick Start Guide

The following information is designed to guide you through a simple setup of a standard sport plane or unpowered glider. The operations shown during this exercise will help you understand many of the basic programming steps used by the Flash 7.



Note

If you are setting up a powered or un-powered glider, we will be programming your plane into the ACRO menu for this exercise. Later you can explore the functions found in the GLID menus.

Channel Assignments for a Simple Powered Plane with One or Two Aileron Servos:

- Channel 1 - Aileron
- Channel 2 - Elevator
- Channel 3 - Throttle
- Channel 4 - Rudder
- Channel 5 - Aileron #2 (if used)

Channel Assignments for a Simple Un-Powered Glider:

- Channel 1 - Aileron (plug rudder or aileron servo in Ch. #1)
- Channel 2 - Elevator

This exercise assumes two things:

1. That you have already installed the servos in your aircraft.
2. That you bound (linked) the receiver to your transmitter.



Warning

For safety reasons during this set-up exercise on an electric powered plane, remove the propeller.

1. Turn on the transmitter. Do not turn on the airplane.
2. When prompted if you are "Ready to Transmit" select "No".
3. Press the jog dial and back button simultaneously to enter the System Menu list.
4. From the System Menu list choose MDL.SEL to enter the model setup.
5. Select the first default model (NONAME-1) and press the jog dial to bring up the model maintenance prompts. Select "NEW" to create a new model.

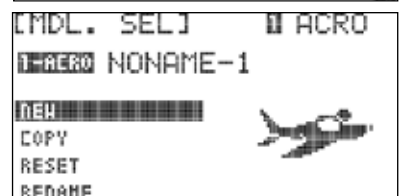
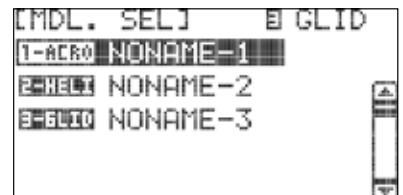
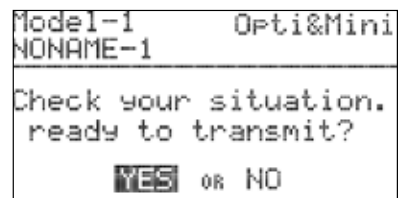

Airplane Quick Start Guide cont.**Note**

We are programming a new model into the model memory slot number two, not the model memory slot one. For the purpose of this exercise it will ensure a fresh model memory with no existing programming.

6. When asked to create a new model select "Yes." This will bring up the Model Type screen.

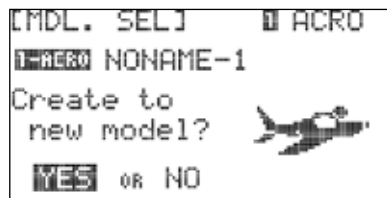

Scroll to "Acro/Glid" or "Select Acro/Glid."

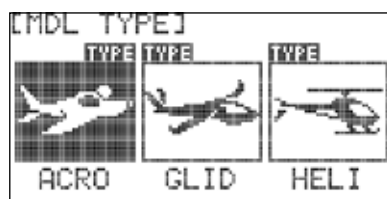

Now scroll to "wing" and press the jog dial to activate the choices. If you have 1 aileron servo, select 1AILE. If your plane has two aileron servos, select 2AILE. Press the jog dial once to confirm your selection.

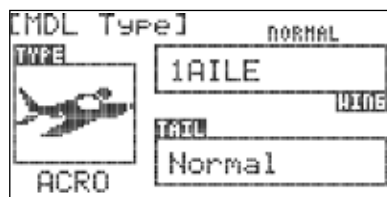
**Note**

Depending on what you select here, and for the following menu choices, the radio will automatically optimize the functions for your choices. In other words, if you select a wing type without flaps, there will be no flap function control in that model memory's programming selection.

7. Next, select your plane's tail type. Select "Normal" and press the jog dial once to confirm your entry .

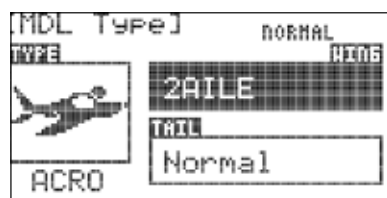

8. Now press the back button once. You will be prompted to choose the receiver type. Press the jog dial once to activate the receiver selections and scroll to the receiver you have in your aircraft. Press the jog dial once to confirm your receiver selection.

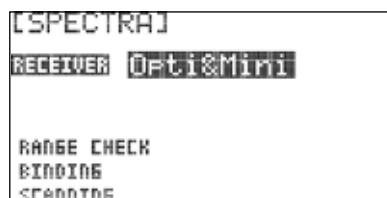

Airplane Quick Start Guide cont.



Note

If your receiver is not bound/linked to your transmitter you will need to follow the procedures on pages 18-19 to do so.

9. Turn your transmitter off and then back on. When prompted to transmit, this time select "Yes." You are now ready to fly a simple model with basic settings. If a more complex setup is needed, refer to sections 4 and 5 for more detailed programming instructions.

Helicopter Quick Start Guide

The following information is designed to guide you through a simple setup of a basic 120 cyclic collective pitch mixing (CCPM) helicopter with a fly bar. The operations shown during this exercise will help you understand many of the basic programming steps used by the Flash 7 when programming a basic helicopter setup.

Channel Assignments

- Channel 1 – Roll Cyclic / Aileron
- Channel 2 – Pitch Cyclic / Elevator
- Channel 3 – Throttle
- Channel 4 – Tail Rotor Pitch / Rudder
- Channel 5 – Gyro Function
- Channel 6 – Collective Pitch

1. Turn on the transmitter. Do not turn on the helicopter.
2. When prompted if you are "Ready to Transmit" select "No."
3. Press the jog dial and back button simultaneously to enter the System Menu list.
4. From the System Menu list choose MDL.SEL to enter the model setup.

```
Model-1      Opti&Mini
NONAME-1

Check your situation.
ready to transmit?

  YES  OR NO
```

```
SYSTEM.LIST
MDL.SEL  SENSOR
MDL TYPE SPECTRA
CHANNEL  MODE
TRIM STEP MANAGEMENT
TRAINER  INFO.
```

```
[MDL.SEL]  B GLID
T-ACRO NONAME-1
B-HELI NONAME-2
B-GLID NONAME-3
```

Helicopter Quick Start Guide cont.

5. Select the first default model (NONAME-1) and press the jog dial to bring up the model maintenance prompts. Select "NEW" to create a new model.

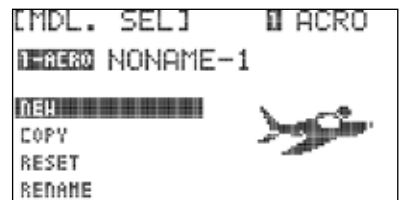
**Note**

We are programming a new model into the model memory slot number two, not the model memory slot one. For the purpose of this exercise it will ensure a fresh model memory with no existing programming.

6. When asked to create a new model select "Yes." This will bring up the Model Type screen.

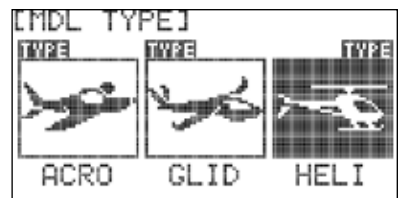

- Select HELI to advance to Swash Type. Scroll to Swash Type and press the jog dial to activate the choices.

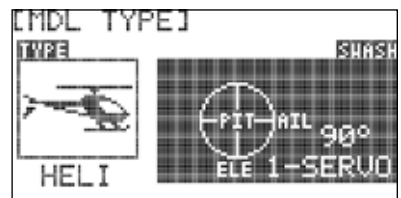

7. Scroll through the Swash Type entries until you see 120° 3-SERVO. Press the jog dial to confirm your entry.

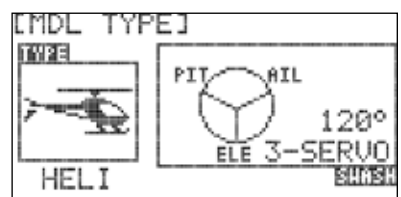

8. Now press the back button once. You will be prompted to choose the receiver type. Press the jog dial once to activate the receiver selections and scroll to the receiver you have in your aircraft. Press the jog dial once to confirm your receiver selection.

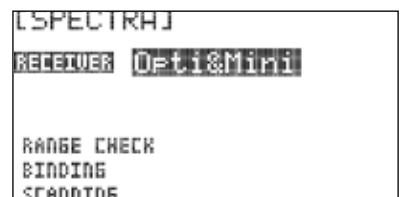

9. Turn your transmitter off and then back on. When prompted to transmit, this time select "Yes." You are now ready to fly a simple helicopter with basic settings. If a more complex setup is needed, refer to sections 4 and 5 for more detailed programming instructions.

System Menu

There are two primary menus in the Flash 7 programming structure. The System function Menu and the Model function Menu. The first menu we will explore is the System Menu. This menu has all the common programming function that are available for ACRO, GLID and HELI models. There are also numerous options for customizing the operating characteristics of the Flash 7 transmitter.



If you have not already programmed a model with the preceding quick start guide, we encourage you to do so before tackling the System and Model programming sections of the manual.

From the System Menu you can do the following:

MDL.SEL: Model Select Menu.

SELECT: Select an existing model.

NEW: Create a new model.

COPY: Copy one model's data into a new model memory slot.

RESET: Reset the model memory to the factory defaults.

DELETE: Delete a model memory.

RENAME: Rename the model to a name of your choice.

MDL TYPE: Model Type Menu.

ACRO: Provides programming for most powered fixed wing aircraft.

GLID: Provides programming for Gliders both powered and unpowered.

HELI: Provides Helicopter programming functions.

CHANNEL: Model channel assignment Menu. Allows control of any channel to be assigned to a switch or joystick axis.

TRIM STEP: Trim step size adjustment menu (1-200). Default is 12.

TRAINER: Trainer options menu.

SENSOR: Telemetry sensor setup menu.

SPECTRA: Receiver set-up.

Range Check Mode: Power down mode for performing preflight range check.

Binding: Use to bind a new receiver to your Flash 7.

Scanning: Scan the frequency table for the clearest channels.

MODE: Stick mode change Mode 1-4.

MANAGEMENT: System Management Menu.

BACKLIGHT: Adjusts how long the backlight stays on.

CONTRAST: Adjusts the screen contrast.

BATTERY: Used to specify the battery type used in the transmitter: Alkaline, NiMh/NiCD, LiPo or LiFe.

System Menu cont.

UI FEEDBACK: Turns the user interface sound feedback on or off.

WARNING SETUP: Controls the various transmitter warnings

RF CHECK: Prompts if you are “Ready to Transmit”

HIGH THROTTLE: Warns if the throttle is not in “idle” position

FLIGHT CONDITION: Warns if a flight condition switch is on

INFO: Displays transmitter information such as software version.

Working with the System Menu

1. Turn on the transmitter. When prompted with the “Ready to Transmit?” message, highlight “NO” and press the jog dial.

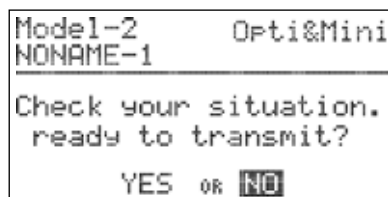

2. To access the system menu simultaneously press the back button and jog dial.

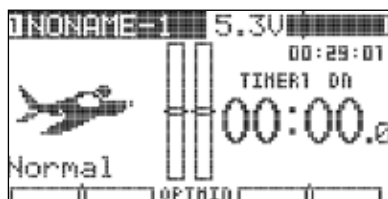

3. The resulting list displays all the features of the system menu associated with the active model. Full explanations of their function can be found in the following text.



Model Select Menu

The Model Select menu can be accessed two different ways. One method is to highlight the model name in the main screen and press the jog dial button. The other method is to select “MDL. SEL” from the system menu.

From the model select menu you can:

- Create a new model
- Select an existing model to use
- Copy one model's data into a fresh model memory slot
- Reset the model memory to factory default settings
- Delete a model
- Rename a model

Model Select Menu cont.

1. Create a new model: When you create a new model, you are also prompted to do other setup items. To avoid repetitive information it is recommended that you read the quick start guides in order to understand what other steps are required when creating a new model. The “New” option is only available if the last model in the list is selected.

System.List	
MDL SEL	Sensor
MDL Type	Spectra
Channel	Mode
Trim Step	Management
Trainer	INFO

2. Select an existing model:

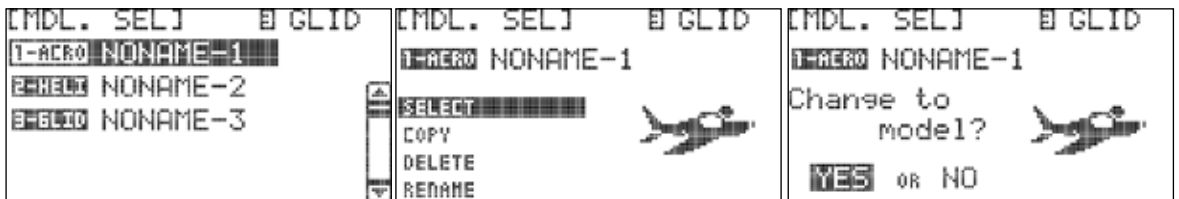

- Use the jog dial to scroll through the list of models. When you have highlighted the model you want to work with, press the jog dial to confirm your selection.
- Highlight “SELECT” and press the jog dial.
- When asked if you would like to change the model, highlight “YES” and press the jog dial.

3. Copy one model’s data into another memory slot:

a. If you haven’t already done so, create a new model by following the ACRO or HELI Quick Start instructions.

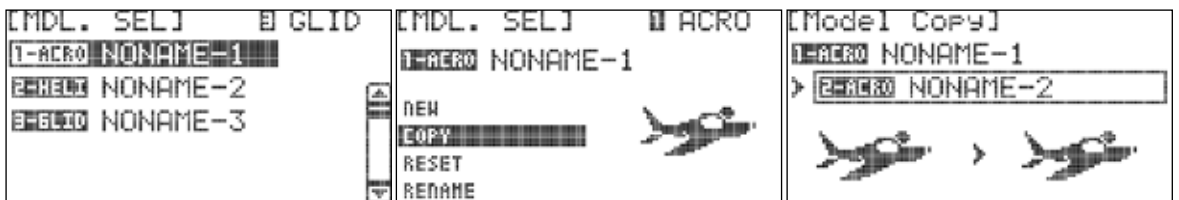

- In the model select menu, highlight the model you wish to copy and press the jog dial.
- Scroll to “COPY” and press the jog dial to activate the destination menu.
- Scroll to select the model memory slot where you would like to place the data. Press the jog dial to confirm your selection.
- When prompted to confirm that you want to copy, select “YES” and press the jog dial to confirm your selection.

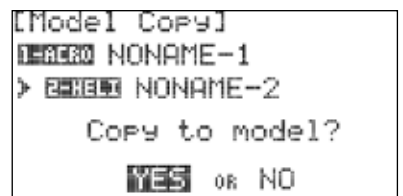

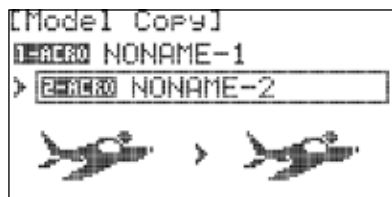
Model Select Menu cont.**4. Reset the active model memory slot to factory default settings:**

a. Select the model you wish to reset.

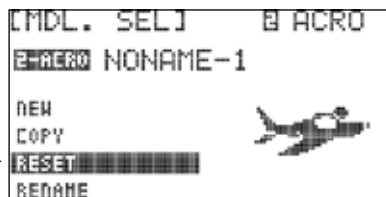

b. Scroll to "RESET" and press the jog dial.

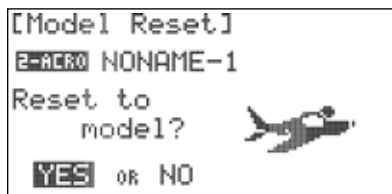

c. When prompted that you want to reset the model, select yes and press the jog dial to confirm your entry. You have now cleared all of the programming for the model. The only settings that will remain are the model name, receiver type and wing and tail types.



Note

You can only reset the active model.

5. Delete a model memory:

a. In the model select menu, highlight the model you wish to delete and press the jog dial.



Note

You cannot delete the active model.

b. Scroll to "DELETE" and press the jog dial.

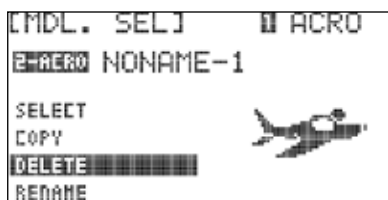

c. When prompted that you want to delete the model, select yes and press the jog dial to confirm your entry.

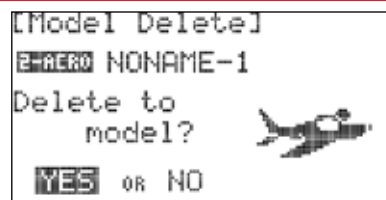
**6. Rename a model:**

a. In the model select menu, highlight the model you wish to rename. Press the jog dial to confirm your selection.

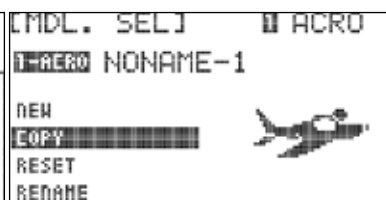
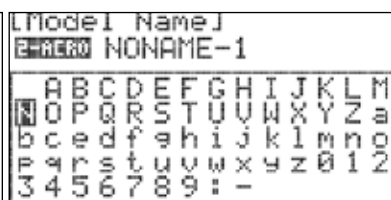

b. Scroll to RENAME and press the jog dial to enter the naming screen.

c. In the field displaying the current model name, scroll to the character you want to change and press the jog dial to activate it. The cursor will blink under the active character.

d. Use the jog dial to scroll through the characters and press it once to select the character.

e. Repeat steps c and d until you have renamed the model.

f. Press the back button to return to the model select menu.

Model Type Menu

The model type screen defines the features of the active model. These are the features we told the radio our model had during the “create a new model” process plus all the default features. Here we can define all the choices you have while setting up your aircraft in the Flash 7.

There are three types of aircraft “Model Type” menus:



ACRO: For all fixed wing, glow, gas and some electric powered models.



GLID: For all gliders and some electric powered models.



HELI: All Helicopters will use the HELI menu.

Model Type ACRO Menu Programming

1. From the System Menu select MDL TYPE.



2. Press the jog dial once to enter the Model Type Selection Menu. ACRO is the first and default selection.

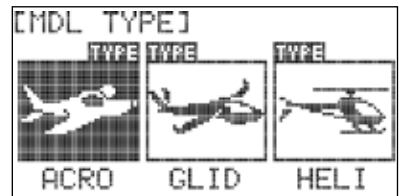

3. Press the jog dial again to enter the ACRO setup menu.

4. Once in the ACRO setup menu you will set your wing and tail choices. Scroll to the wing selection and press the jog dial to activate the selections and scroll through the choices.

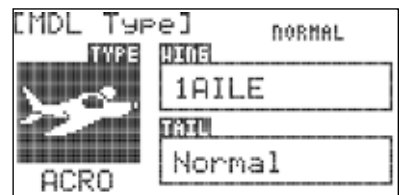

The choices for Normal ACRO wing type are:

- 1AILE – Single aileron servo
- 1AILE+1FLAP – Single aileron servo and single flap servo
- 1AILE+2FLAP - Single aileron servo channel and two flap servos
- 2AILE – Two aileron servos
- 2AILE+1FLAP - Two aileron servos and one flap servo
- 2AIL+2FLAP - Two aileron servos and two flap servos

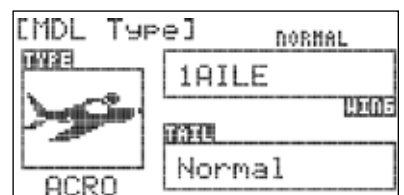

Model Type ACRO Menu Programming cont.

Additionally there are setups for delta wing type models (Elevon):

- 2AILE
- 2AILE+1FLAP
- 2AILE+2FLAP

5. Once you have selected your wing types, press the jog dial to confirm your selection.

6. Scroll to "TAIL" and press the jog dial to activate the menu. The choices for tail type are dependent on the type of wing you selected.

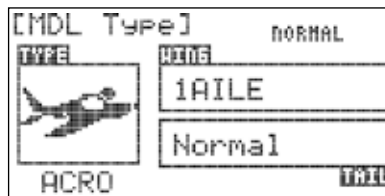

The tail types you may choose with the basic ACRO wing types are:

NORMAL:

Rudder is located on a vertical stabilizer and elevator is on a horizontal stabilizer.

V-TAIL:

Two control surfaces in a V-configuration operate together providing both yaw (rudder) and pitch (elevator) control.

Ailevator:

Each half of the elevator is controlled by a dedicated servo to provide pitch (elevator), and roll (aileron) control.

The tail choices if you chose one of the Delta Wing types are:

- None: For Delta Wing Models without a rudder.
- 1Servo: For Delta Wing Models with a single rudder servo.
- 2Servo: For Delta Wing Models with dual rudder servos.

7. Select the tail type that your model has and press the jog dial to confirm your selection.

8. Use the back button to return to the system menu.

Model Type GLID Menu Programming

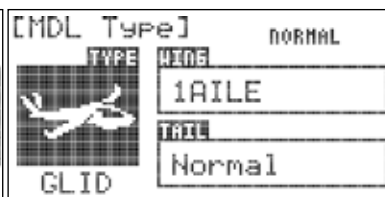
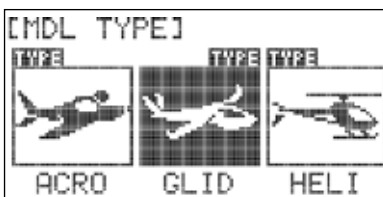

1. From the System Menu select MDL TYPE.
2. Press the jog dial once to enter the Model Type Selection Menu. Scroll to model type GLID.
3. Press the jog dial again to enter the GLID setup menu.

Model Type GLID Menu Programming cont.

4. Once in the GLID setup menu you will set your wing and tail choices. Scroll to the wing selection and press the jog dial to activate the selections and scroll through the choices.

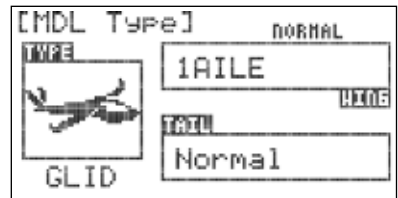

The choices for Normal GLID wing type are:

- 1AILE – Single aileron servo
- 1AILE+1FLAP – Single aileron servo and single flap servo
- 1AILE+2FLAP - Single aileron servo channel and two flap servos
- 2AILE – Two aileron servos
- 2AILE+1FLAP - Two aileron servos and one flap servo
- 2AIL+2FLAP - Two aileron servos and two flap servos

Additionally there are setups for Delta wing type models (Elevon):

- ELEVON
- ELEVON+1FLAP
- ELEVON+2FLAP
- DELTA

5. Once you have selected you wing type, press the jog dial to confirm your selection.

6. Scroll to the Tail selection menu and press the jog dial to activate the selections and scroll through the choices. The choices for tail type are dependent on the type of wing you selected.

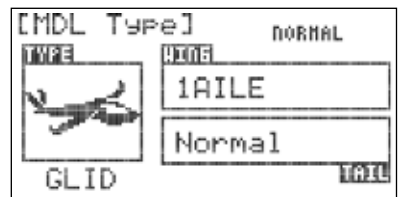

The tail types you may choose with the basic GLID wing types are:

NORMAL:

Rudder is located on a vertical stabilizer and elevator is on a horizontal stabilizer.

V-TAIL:

Two control surfaces in a V-configuration operate together providing both yaw (rudder) and pitch (elevator) control.

Ailevator:

Each half of the elevator is controlled by a dedicated servo to provide pitch (elevator), and roll (aileron) control.

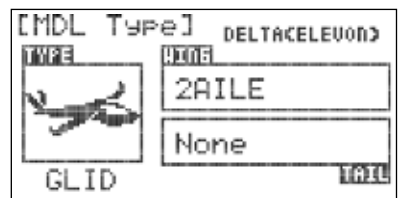

The tail types you may choose with delta wing types are:

- None: For Delta Wing Models without a rudder.
- 1Servo: For Delta Wing Models with a single rudder servo.
- 2Servo: For Delta Wing Models with dual rudder servos.

7. Select the tail type that your model has and press the jog dial to confirm your selection.

8. Press the back button to return to the system menu.

Model Type HELI Menu Programming

1. From the System Menu select MDL TYPE.

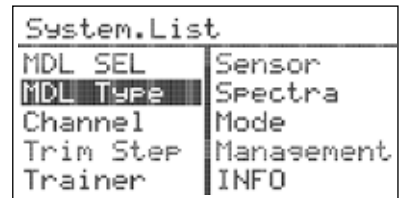

2. Press the jog dial once to enter the Model Type Selection Menu and scroll to HELI.

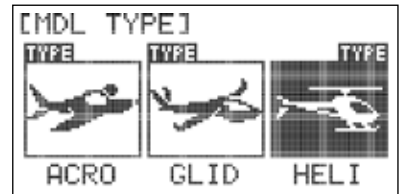

3. Press the jog dial once to enter the HELI setup menu. to enter the HELI setup menu.

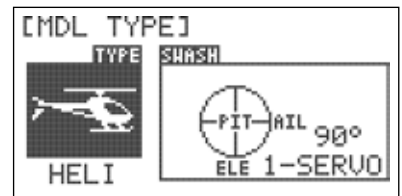

4. In the HELI menu you will set the swash type. Scroll to highlight "SWASH" and press the jog dial to activate the menu.

There are three types of Swash types to choose from:

90° 1 servo: The three swash servos are configured 90° apart, and each servo provides independent control of collective, pitch, or roll.

120° 3 servos: The three swash servos are configured 120° apart, and all servos operate in unison to control collective, pitch, and roll.

140° 3 servos: The three swash servos are configured 140° apart, and all servos operate in unison to control collective, pitch, and roll.

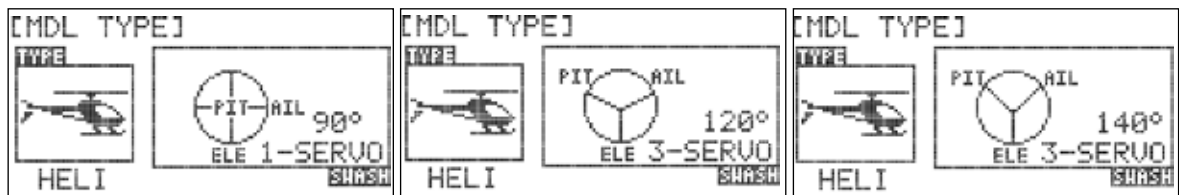

Your helicopter's manual will indicate the type of swashplate on your model.

5. Select the Swash type that your helicopter has and press the jog dial to confirm your selection.

6. Press the back button to return to the system menu.

Channel Selection Menu

The Channel menu allows you to choose the function (AILE, THRO, RUDD, etc.) and control input method (joystick, switch, slider, etc) for each channel. This programming function permits a high level of creativity in the way you can customize the Flash 7 to suit your personal flying style.

1. From the System Menu scroll to CHANNEL and press the jog dial to enter the Channel selection menu.

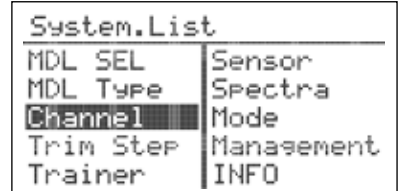

Default channel assignments are based on the Model Type, Wing, Tail and Swash type setups. However you can assign any channel to any function or transmitter control.

2. To assign a channel to a specific function, scroll to highlight the channel you want to assign and press the jog dial to enter the menu.

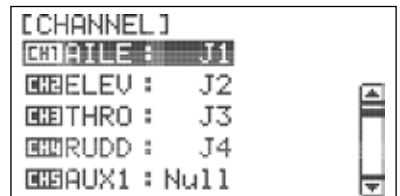

3. Scroll to the channel function field (AILE, ELEV, etc.) and press the jog dial to activate the selection menu.
4. Scroll through the choices to select the desired function of that channel and press the jog dial to confirm your selection

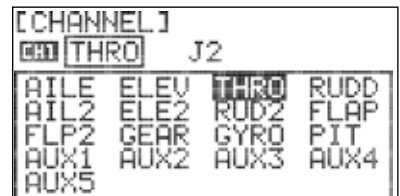

5. To assign a channel to a specific transmitter control, scroll to the input device field (J1, LS, etc.) and press the jog dial to activate the selection menu.
6. Scroll through the choices to select the desired transmitter control you want to use for that channel and press the jog dial to confirm your selection.

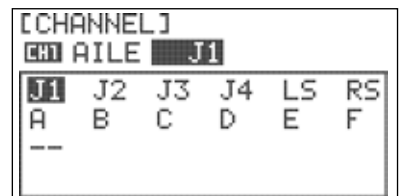

The Flash 7 has two Virtual Channels VC1 & VC2. The virtual channels can only be assigned to a transmitter control and then mixed with another channel in the programmable mix function. For more information on the use of virtual channels see the programmable mix functions in the model programming sections beginning on page 49.

7. Use the back button to exit the Channel Function/Control selection menu.

Trim Step

The Trim Step screen is utilized to change the amount of movement seen on the servos with each adjustment, or “beep” of the gimbal trim levers. Larger values equate to greater servo movement with each trim adjustment.

1. From the System Menu scroll to TRIM STEP and press the jog dial to enter the Trim Step Menu.



2. Scroll to the trim you want to adjust and push the jog dial to activate the adjustment. Use the jog dial to change the value and press it to confirm your entry. Trim Step adjustment values are from 1~200.

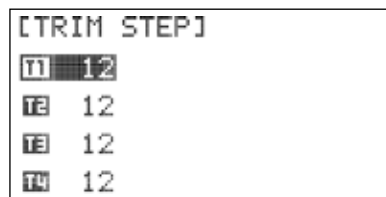

3. Use the back button to exit the Trim Step Menu.

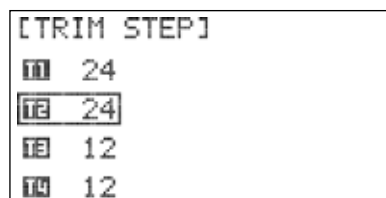

4. Press the back button return to the system menu.

Trainer Function

The Flash 7 can be paired with another Hitec transmitter to create a master/slave setup that is useful when instructing student pilots. The Flash 7 can be used to help teach students how to fly utilizing the various trainer functions of the transmitter.

Utilizing the various trainer functions of the Flash 7, you can:

- Select which controls (RUDD, THRO, AIL, ect.) the student will command.
- Use the mix feature to give the student a percentage of the control throw while the master has the remainder.

In addition to training, you can also use the Flash 7's pass-through function to control head tracking devices for First Person View flying.



Note

The Flash 7 is compatible with all other Hitec transmitter products using the 3.2mm stereo plug.



Warning

When using the Flash 7 in trainer mode, the following items must be verified before flying:

- The master radio must be programmed with the model to be flown.
- The slave or student transmitter must have the proper servo reverse and trim settings to match the master transmitter.

Trainer Function cont.

Within the trainer menu, you can set the Flash 7 as a “Master radio”, set the trainer switch, and activate the other features. To do this, the transmitter must be in transmit mode. If not in the transmit mode, the only options you will have are the “pupil” options.

To configure the trainer function:

1. From the system menu, scroll to highlight “TRAINER” and press the jog dial once to enter the activation menu.



2. Press the jog dial again to activate the menu.

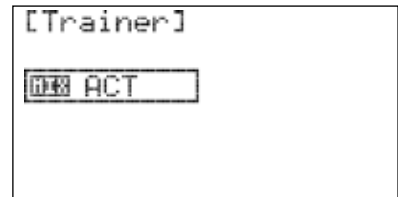

3. Rotate the jog dial to select “ACT” (activate), then press the jog dial to confirm your selection and activate the trainer menu.

4. Scroll to highlight “MODE” and press the jog dial to activate the menu.

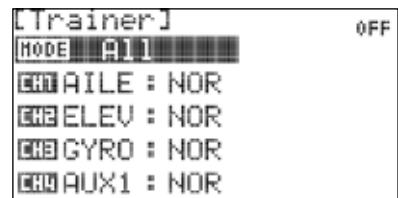

5. Scroll to select the number of channels the student radio can control:

ALL – Gives the student access to all control channels 1~7.

STICK – Gives the student access only to the stick (gimbal) channels 1~4.

Press the jog dial to confirm your selection.

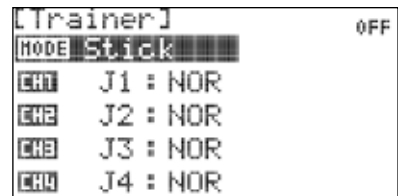

Note

Within the trainer function menu you can choose to limit the control the student has by selecting one of the three choices; NOR for full control, MIX for limited control or OFF for no Control.

6. Within the trainer menu, you can choose to limit the control the student has for each channel by selecting one of the three choices:

- NOR for full control.
- MIX for limited control.
- OFF for no Control.

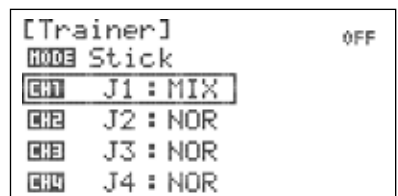

7. To adjust the level of control for any channel, scroll to the channel you want to change and press the jog dial to activate the selections.

8. Scroll to select “NOR”, “MIX”, or “OFF” and press the jog dial to confirm your selection.

Trainer Function cont.

9. To select which switch will be used for the trainer function scroll down to the S/W field and press the jog dial to enter the switch selection menu. Press the jog dial again to activate the switch selections.

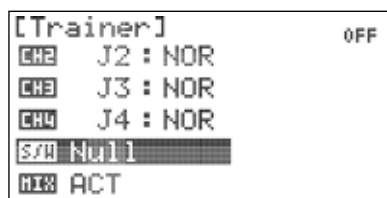

10. Scroll to select a switch to activate the trainer function. Press the jog dial to confirm your selection.

- If you choose the "NULL" option, the Trainer function will remain inactive at all times for this model.

- If you choose a switch:

- The switch position menu will appear. Scroll to highlight the switch position that you will use to enable the mix. Press the jog dial to confirm your selection.

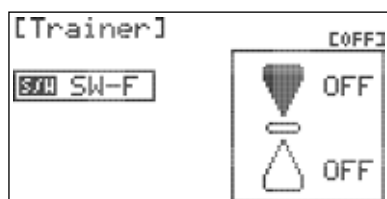

- Scroll to select "ON" and press the jog dial to confirm your selection. If you toggle the selected switch, the field in the top right corner of the screen will indicate when the mix is active.

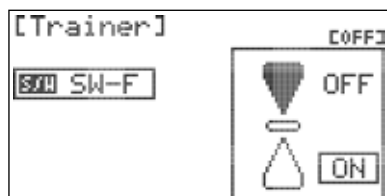

11. Press the back button twice to return to the trainer menu.

To disable the trainer function:

1. Scroll to highlight the "MIX" field in the trainer menu and press the jog dial to activate the menu.
2. Select "INH" (inhibit) and press the jog dial to confirm your selection.
3. Press the back button to return to the system menu.

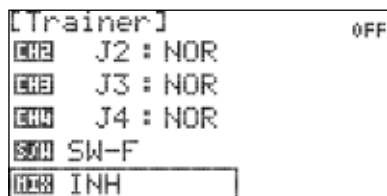
**Sensor**

When used with the Optima series of telemetry capable receivers, the Flash 7 has the ability to communicate a variety of information from the airplane directly to the transmitter. Refer to Section Seven Using the Telemetry System on page 96 for more information.

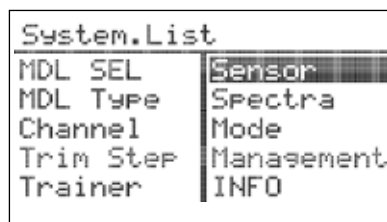
**Spectra**

The spectra menu is utilized to manage the interface between the Flash 7 transmitter and the receiver for each aircraft. This includes specifying the receiver type, performing a range check, binding the receiver, and specifying a frequency scan. All of these functions are covered in Section One: Introduction - Hitec 2.4GHz System. Please refer to page 14 for complete information on the spectra menu.

Control Modes

The Flash 7 is capable of operating in control Modes 1 ~ 4. The default is mode 2 for models sold in North America as this is generally preferred by the majority of pilots.

1. From the system menu, scroll to highlight "MODE" and press the jog dial to enter the mode selection menu.
2. Press the jog dial again to activate the mode selections.

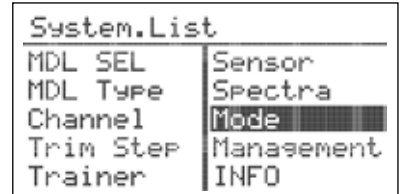

3. Scroll through the modes until you find the one you would like to use. The selected mode will be applied to each new model that is created. Press the jog dial to confirm your selection.

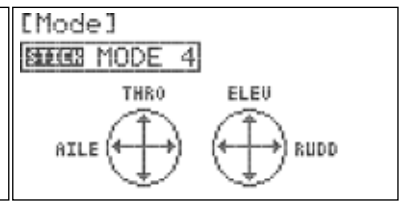
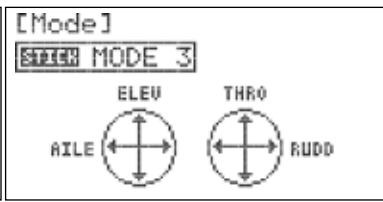
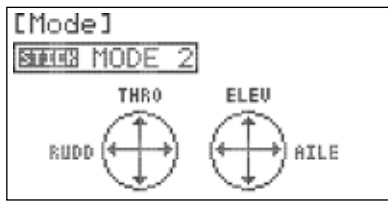
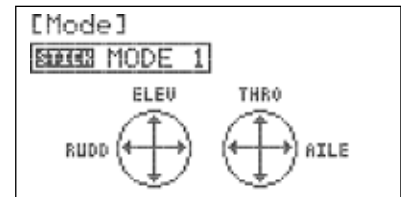

Some modes require additional adjustments to the hardware of the Flash 7 transmitter. For more information on the Flash 7's hardware adjustments refer to Appendix A. Hardware adjustments.

Management Menu

The Management menu allows you to tailor numerous system-wide features of the Flash 7.

From the management menu, you can control the following:

- User Interface screen backlight duration and contrast.
- Battery type used in the transmitter.
- UI Feedback - Audible tones during warnings and when you press or scroll the jog dial.
- Warning Setup – Audible warnings when the transmitter is powered on.

1. To enter the Management menu scroll to MANAGEMENT from the System Menu and press the jog dial to enter the menu.



2. Scroll to highlight "BACKLIGHT" and press the jog dial to activate the menu.
3. Scroll to select the amount of time that the screen backlight will stay active without manipulating the jog dial or back button. Press the jog dial to confirm your selection.

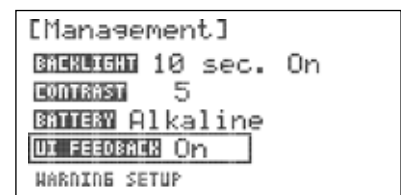

Management Menu cont.

4. Scroll to highlight "CONTRAST" and press the jog dial to activate the menu.
5. Scroll to adjust the contrast level of the display screen. Press the jog dial to confirm your selection.
6. Scroll to highlight "BATTERY" and press the jog dial to activate the menu.
7. Scroll to select the battery type used in the transmitter. Press the jog dial to confirm your selection.

```
[Management]
BACKLIGHT 10 sec. On
CONTRAST 5
BATTERY Alkaline
UI FEEDBACK On
WARNING SETUP
```

```
[Management]
BACKLIGHT 10 sec. On
CONTRAST 5
BATTERY Alkaline
UI FEEDBACK On
WARNING SETUP
```



Warning

The operating voltages of Alkaline and NiCd/NiMh batteries are below the safe discharge voltages for LiFe and LiPo battery types. Selecting a LiFe or LiPo battery type in the menu when the actual battery is Alkaline or NiCd/NiMh will cause the Flash 7 to shut down due to low-voltage settings.

8. Scroll to highlight "UI FEEDBACK" and press the jog dial to activate the menu.
9. Scroll to select "ON" or "OFF". When user interface feedback is turned on, the radio emits a beep each time the jog dial is scrolled or pressed. The transmitter will emit continuous beeps if a warning is active. Press the jog dial to confirm your selection.
10. Scroll to highlight "WARNING SETUP" and press the jog dial to activate the menu.

```
[Management]
BACKLIGHT 10 sec. On
CONTRAST 5
BATTERY Alkaline
UI FEEDBACK On
WARNING SETUP
```

```
[Management]
WARNING SETUP
RF CHECK On
HIGH THROTTLE On
FLIGHT CONDITION On
```

11. Scroll to highlight "RF CHECK" and press the jog dial to activate the menu.
12. Scroll to select "ON" or "OFF". When RF check is turned on, the radio will prompt you to approve signal transmission each time the unit is powered on. Otherwise, the radio will automatically begin transmitting when powered on. Press the jog dial to confirm your selection.

```
[Management]
WARNING SETUP
RF CHECK On
HIGH THROTTLE On
FLIGHT CONDITION On
```

13. Scroll to highlight "HIGH THROTTLE" and press the jog dial to activate the menu.
14. Scroll to select "ON" or "OFF". When high throttle is turned on, the radio will warn you if the throttle stick is not at idle when the unit is powered on. Press the jog dial to confirm your selection.

```
[Management]
WARNING SETUP
RF CHECK On
HIGH THROTTLE On
FLIGHT CONDITION On
```

Management Menu cont.

15. Scroll to highlight "FLIGHT CONDITION" and press the jog dial to activate the menu.
16. Scroll to select "ON" or "OFF". When the flight condition warning is turned on, the radio will warn you if any programmed flight conditions are active when the unit is powered on. Press the jog dial to confirm your selection.
17. Press the back button twice to return to the system menu.

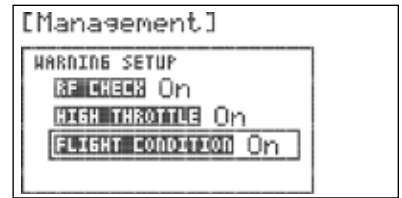
**INFO**

The Info screen displays the current firmware information for the radio.

1. From the system menu, highlight "INFO" and press the jog dial once to see the information.
2. Press the back button to return to the system menu.

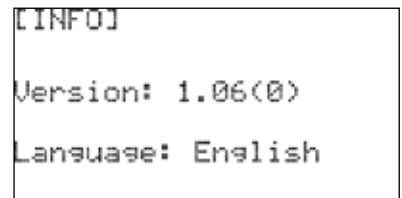

Common Model Programming Menu

The Model Function menu contains options that relate to all model types (common) as well as options which are specific to fixed wing models (ACRO/GLID) or helicopters (HELI). This section illustrates the common model function options. The features specific to fixed wing or helicopter model types are covered in Section Five and Section Six respectively.



If you have not already programmed a model with the preceding quick start guide, we encourage you to do so before tackling the model programming section of the manual.

From the Model Function menu, you can program the following common functions:

REVERSE: Specify the direction that a servo will travel with a given control input.

SUB TRIM: Fine-tune the neutral point of a servo.

D/R & EXP: Specify Dual-Rate and Exponential settings for control surface servos.

EPA: Specify the servo travel limits for channels 1-7.

S.Speed: Specify the transit speed for servos on channels 1-7.

PROG.MIX: Configure up to three user-programmable mixes.

TIMER: Configure two user-programmable timers.

MONITOR: Observe graphic feedback to control inputs.

Working with the Common Model Function Menus

1. Turn on the transmitter. When prompted with the "Ready to Transmit?" message, highlight "NO" and press the jog dial.

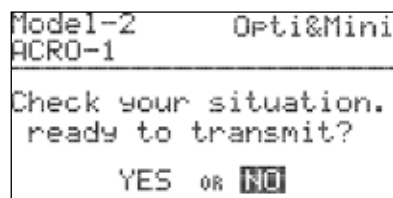

2. To access the model function menu, press and hold the jog dial.

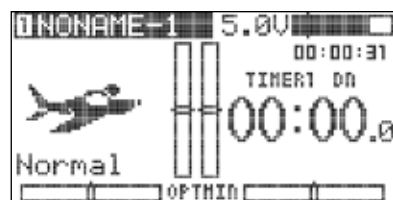

3. The menu options shown reflect the parameters defined for the active model in the model type menu (Model Type, Wing, Tail, Swash). Common model items are integrated with the fixed-wing and helicopter-specific options in the menu.

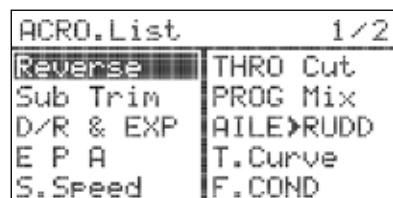

Servo Reverse

The Reverse screen allows you to specify the direction of servo rotation for channels 1-7 of the active model.

1. From the model menu, scroll to highlight "REVERSE" and press the jog dial once to enter the reverse menu.



2. Scroll to the channel to be reversed and press the jog dial to activate the selections:

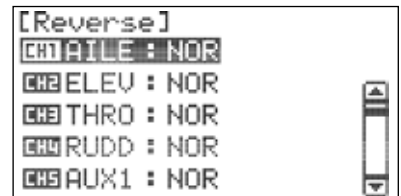

NOR (default): Normal rotation.

REV: Reverse rotation.

3. Once you have chosen the desired direction, press the jog dial to confirm your selection.

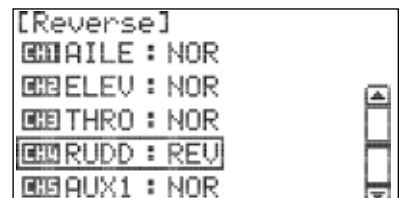

4. Press the back button to return to the model menu.

Sub Trims

The Sub Trim menu is used to make very fine adjustments to the center point, or "neutral point" of a servo. It is typically preferable to have the servo arm 90° to the pushrod at the neutral point. Use sub trim settings to attain this orientation. Then, adjust the length of the pushrod to achieve the desired neutral control surface position.

1. From the model menu, scroll to highlight "SUB TRIM" and press the jog dial once to enter the sub trim menu.

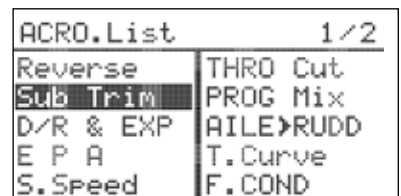

2. Scroll to the channel to be adjusted and press the jog dial to activate the menu.

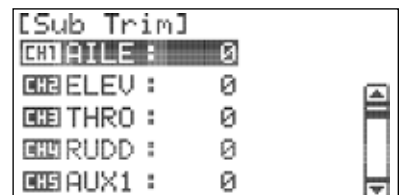

3. Rotate the jog dial clockwise or counter-clockwise to alter the servo neutral point.

4. Once you have achieved the desired neutral point, press the jog dial to confirm your change.

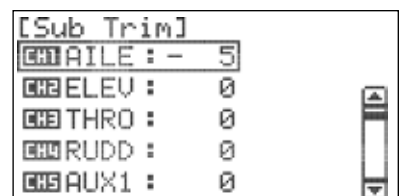

5. Press the back button to return to the model menu.

Dual Rates and Exponentials

The Dual Rate (D/R) feature provides a method to define two different values of servo movement (“rates”) on the same channel. You may want low control rates during takeoff and landing and higher rates when performing aerobatics. One or more switches are assigned to allow the pilot to select high or low rates.

Exponential Rate (“EXP”) is a powerful function that is often used to make a twitchy model easier to control. Negative exponential values typically make a model less sensitive to moderate control inputs, yet you still have the same amount of overall control throw. Positive exponential values are generally detrimental to a model’s controllability and should be avoided.



Tip

Before entering the D/R & EXP menu, it is helpful to decide which switch or switches you want to control dual rates, as well as the switch positions that will be used for high-rates and low-rates. The same switch can be used to manage dual rates for one or more control functions.

Dual Rates

1. From the model menu, scroll to highlight “D/R & EXP” and press the jog dial once to enter the D/R & EXP menu.



2. Scroll to highlight the control function field (RUDD, ELEV, etc) and press the jog dial to activate the menu.

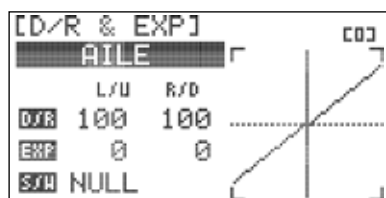

3. Rotate the jog dial to select the desired control function and press the jog dial to confirm your selection.

4. Locate the switch that you will use to control dual rates for this function and move it to the desired position for high-rates.

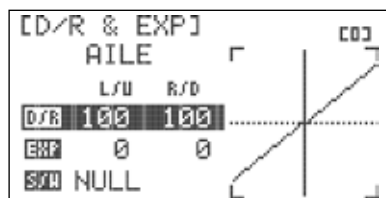

5. Scroll to highlight the “D/R” field and press the jog dial to activate the D/R sub-menu.

6. Scroll to highlight the “L/U” (left/up) field and press the jog dial to activate the menu.

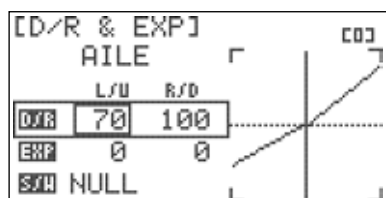

7. Rotate the jog dial to increase (clockwise) or decrease (counter-clockwise) the desired travel for the servo(s) in high-rate mode. The value is a percentage of the available servo throw from neutral to full left (AILE, RUDD) or full up (ELEV). Press the jog dial to confirm your input.

Dual Rates cont.

8. Scroll to highlight the "R/D" (right/down) field and press the jog dial to activate the menu.
9. Rotate the jog dial to increase (clockwise) or decrease (counter-clockwise) the desired travel for the servo(s) in high-rate mode. The value is a percentage of the available servo throw from neutral to full right (AILE, RUDD) or full down (ELEV). Press the jog dial to confirm your input.
10. Press the back button twice to return to the D/R & EXP menu.

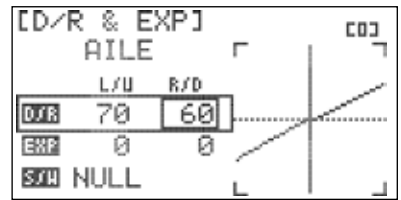

Exponential Rate

11. Scroll to highlight the "EXP" field and press the jog dial to activate the menu.
12. Scroll to highlight the "L/U" (left/up) field and press the jog dial to activate the menu.
13. Rotate the jog dial to increase (clockwise) or decrease (counter-clockwise) the desired exponential value in high-rate mode. This value is applicable for control inputs from neutral to full left (AILE, RUDD) or full up (ELEV). Press the jog dial to confirm your input.
14. Scroll to highlight the "R/D" (right/down) field and press the jog dial to activate the menu.
15. Rotate the jog dial to increase (clockwise) or decrease (counter-clockwise) the desired travel for the servo(s) in high-rate mode. This value is applicable for control inputs from neutral to full right (AILE, RUDD) or full down (ELEV). Press the jog dial to confirm your input.

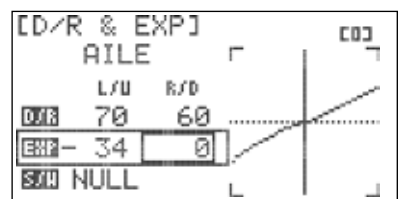
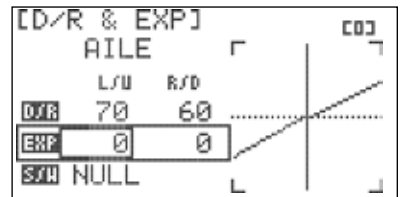
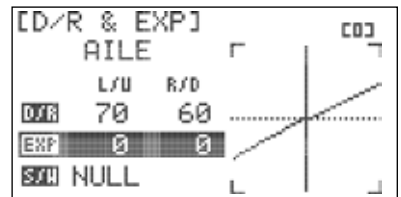

Tip

The on-screen graph provides real-time feedback regarding how your D/R & EXP inputs affect servo movement. Note that the y-axis of the graph moves as you manipulate the relevant control stick for the current function being edited.

16. Press the back button twice to return to the D/R & EXP menu.

Switch Assignment

17. Scroll to highlight the S/W field and press the jog dial to activate the menu.

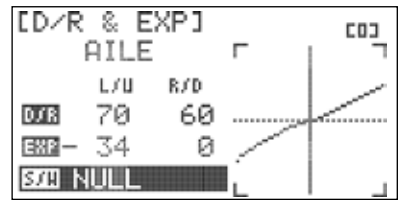

18. Scroll to select the switch you have chosen to control dual rates for this function and press the jog dial to confirm your selection.

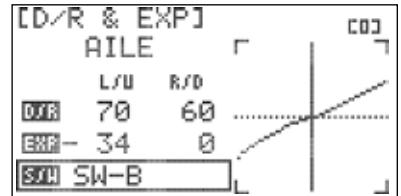

19. Physically move the switch to the desired position for low-rates.

Repeat steps 5-16 to input low-rate throws and exponential values for the selected function.

Repeat steps 4-19 for each control function.



Tip

The final settings in the D/R & EXP menu should reflect the model aircraft manufacturer's suggested control surface deflections for each function. Some manufacturers also provide suggested exponential values.

20. Press the back button to return to the model menu.

End Point Adjustments

The End Point Adjustment (EPA) feature allows you to fine tune the maximum servo movement for every channel. This capability is very useful when dealing with models that require small control movements or in cases where binding/damage could occur from excessive control movement.

1. From the model menu, scroll to highlight "EPA" and press the jog dial once to enter the EPA menu.

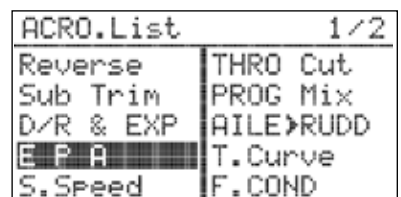

2. Scroll to the control surface to be adjusted and press the jog dial to activate the EPA sub-menu.

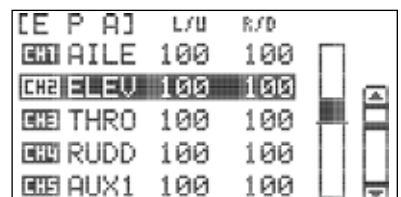

3. Scroll to highlight the "L/U" (left/up) field and press the jog dial to activate the menu.

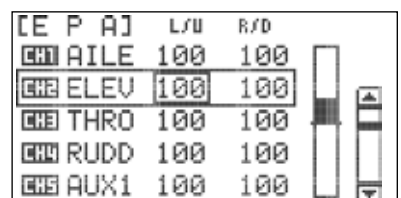

4. Rotate the jog dial to increase (clockwise) or decrease (counter-clockwise) the desired left (AILE, RUDD) or up (ELEV) servo endpoint. Press the jog dial to confirm your input.

End Point Adjustments cont.

5. Scroll to highlight the "R/D" (right/down) field and press the jog dial to activate the menu.
6. Rotate the jog dial to increase (clockwise) or decrease (counter-clockwise) the desired right (AILE, RUDD) or down (ELEV) servo endpoint. Press the jog dial to confirm your input.
7. Press the back button to return to the EPA menu.
8. Repeat steps 2 through 7 for the control surfaces you would like to adjust.
9. Press the back button again to return to the model menu.

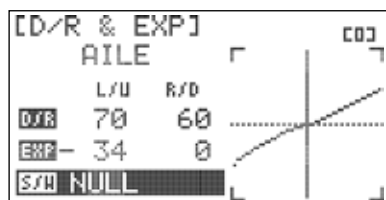

Servo Speed

The Servo Speed (S.SPEED) feature allows you to fine tune the maximum servo movement for every channel. This capability is very useful when dealing with models that require small control movements or in cases where binding/damage could occur from excessive control movement.

1. From the model menu, scroll to highlight "S.SPEED" and press the jog dial once to enter the servo speed menu.



2. Scroll to the channel to be adjusted and press the jog dial to activate the menu.

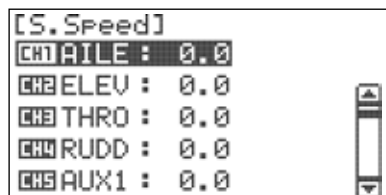

3. Rotate the jog dial clockwise or counter-clockwise to alter the speed of the servo. The selected value is the transit time of the servo in seconds (0-25.0).
4. Once you have achieved the desired servo speed, press the jog dial to confirm your change.
5. Press the back button to return to the model menu.

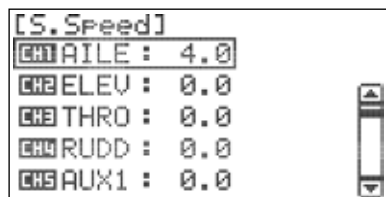

Programmable Mixes

The Flash 7 provides three user-programmable mixes which can be used for a wide variety of custom functions that are not available with the built-in mixes and options. A common use for these mixes is to correct unwanted behavior of an aircraft. This could be automatically applying a bit of rudder with throttle to counteract torque/P-factor effects, or applying elevator during knife-edge flight to correct an undesired tucking tendency. Maybe you just want the head on your model's pilot figure to turn when you taxi out to the runway. Programmable mixes can make it happen.

Virtual Channels & P-Mixes: A 'virtual' channel is essentially a channel created outside of the normal channels that are sent to the receiver. In addition to the 7 actual channels you can use two virtual channels for mixing purposes. These channels exist only in the transmitter and do not use any of the receiver slots. Virtual channels can be assigned to any transmitter control in the channel setup menu as described on page 37 (VC1 & VC2). Through the Programmable Mix feature you can mix this virtual channel with any other channel to accomplish a variety of mixing functions in your model.

Programmable Mixes cont.

Example: Let's say you want to control your ailerons as flaps using one of the slider switches but you don't want to have the slider active all the time in case you accidentally bump it. You can assign the slider to your virtual channel and then P-mix that channel to the aileron servos. Since you have the option to have the P-mix activated with a switch, the slider will only be active when the switch is in the on position. While this is just one example, there are many other uses. If you run into a situation where you cannot get the results you are looking for through normal mixing, consider using the virtual channel along with a P-mix.

1. From the model menu, scroll to highlight "PROG.MIX" and press the jog dial once to enter the programmable mix menu.
2. Scroll to highlight the mix to be configured and press the jog dial to activate the selection.
3. Rotate the jog dial to select ACT (activate), then press the jog dial to confirm your selection and activate the sub-menu for the selected mix.
4. Scroll to select the master/slave field and press the jog dial to activate the menu.
5. Scroll to select the master function field (left field) and press the jog dial to activate the menu.
6. Scroll to select the desired function to be the master function for the mix (THRO, RUDD, GEAR, etc.) and press the jog dial to confirm your selection.
7. Scroll to select the slave function field (right field) and press the jog dial to activate the menu.
8. Scroll to select the desired function to be the slave function for the mix and press the jog dial to confirm your selection. Press the back button to return to the programmable mix sub-menu.
9. Scroll to highlight the "RATE" field and press the jog dial to activate the menu.

```
ACRO.List 1/2
Reverse THRO Cut
Sub Trim PROG Mix
D/R & EXP AILE>RUDD
E P A T.Curve
S.Speed F.COND
```

```
[PROG.MIX]
1 INH
2 INH
3 INH
```

```
[PROG.MIX]
1 ACT
2 INH
3 INH
```

```
[PROG.MIX]
----->----- on
          L/S  R/D
RATE  0    0
EXP   0
TRIM  OFF
```

```
[PROG.MIX]
[AILE]>----- on
          L/S  R/D
RATE  0    0
EXP   0
TRIM  OFF
```

```
[PROG.MIX]
[AILE]>RUDD on
          L/S  R/D
RATE  0    0
EXP   0
TRIM  OFF
```

```
[PROG.MIX]
AILE > RUDD on
          L/S  R/D
RATE  0    0
EXP   0
TRIM  OFF
```

Programmable Mixes cont.

10. Scroll to highlight the "L/U" (left/up) field and press the jog dial to activate the selection.
11. Rotate the jog dial to increase (clockwise) or decrease (counter-clockwise) the desired left (AILE, RUDD) or up (ELEV) servo movement for the slave function. Press the jog dial to confirm your input.
12. Scroll to highlight the "R/D" (right/down) field and press the jog dial to activate the menu.
13. Rotate the jog dial to increase (clockwise) or decrease (counter-clockwise) the desired right (AILE, RUDD) or down (ELEV) servo movement for the slave function. Press the jog dial to confirm your input.
14. Press the Back button twice to return to the programmable mix sub-menu.
15. Scroll to highlight the "EXP" field and press the jog dial to activate the menu.

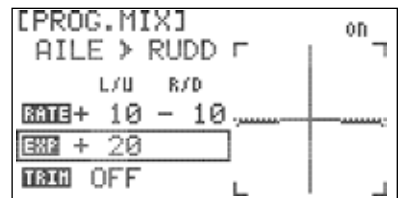
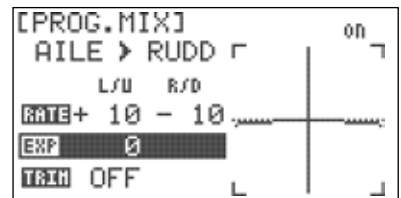
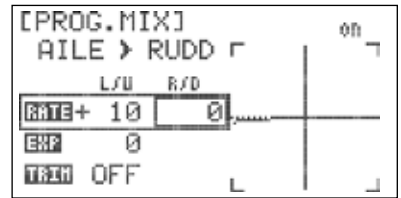
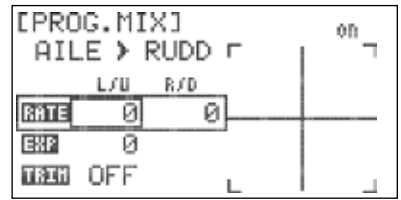

16. Rotate the jog dial to increase or decrease the desired amount of exponential throw on the slave servo when operating with the mix. Press the jog dial to confirm your input.



Tip

See the "D/R & EXP" menu on page 45 for more information about exponential rates.

17. Scroll to highlight the "TRIM" field and press the jog dial to activate the menu. With this feature enabled, the slave feature will respond to trim changes as well as control inputs for the master feature. When disabled, the slave feature ignores trim changes and reacts only with control inputs to the master feature.
18. Rotate the jog dial to select "OFF" or "ON" and press the jog dial to confirm your input.
19. Scroll to highlight "S/W" and press the jog dial to activate the menu.

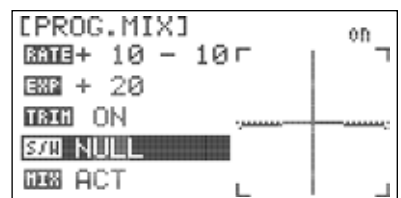
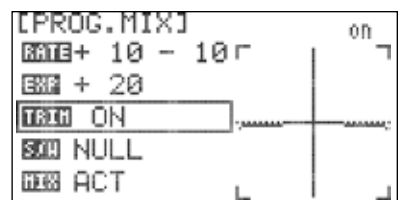

Programmable Mixes cont.

20. Press the jog dial again to enable selections in the S/W menu.
21. Scroll to select the switch that you will use to activate the mix and press the jog dial to confirm your selection. If "NULL" is selected, the mix will always be active.

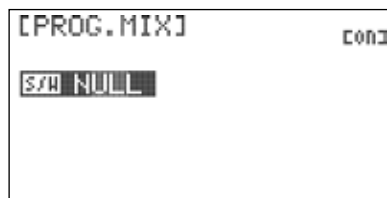

22. If you selected a switch, the switch position menu will appear. Scroll to highlight the switch position(s) that you will use to enable the mix. Press the jog dial to confirm your selection.



23. Scroll to select "ON" and press the jog dial to confirm your selection. If you toggle the selected switch, the field in the top right corner of the screen will indicate if the mix is on or off.



24. Press the back button to return to the programmable mix sub-menu.

25. To inhibit this mix, scroll to the "MIX" field and press the jog dial to activate the menu.

26. Scroll to select "INH" and press the jog dial to confirm your selection.

27. Press the back button twice to return to the model function menu.

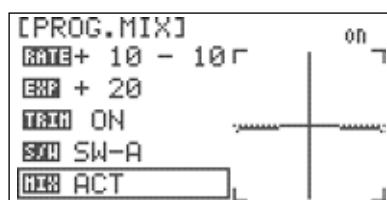
**Timers**

The Flash 7 features two customizable timers that can be triggered by switches or the throttle position. Downward counting timers can be helpful in making sure that you land before running out of fuel or battery power. You could also use an upward counting timer to measure the duration of your glider flights. In addition, there is an integrated timer for each model memory that automatically records the length of time that the Flash 7 is used for that model. All timers are displayed on the home screen.

To configure a timer:

1. From the model menu, scroll to highlight "TIMER" and press the jog dial once to enter the timer menu.

**Note**

You can also enter the timer menu directly from the home screen. Scroll to highlight a timer on the screen and press the jog dial.

Timers cont.

2. Scroll to highlight "INH" under TIMER-1 and press the jog dial to activate the menu.
3. Scroll to select "ACT" (active) and press the jog dial to confirm your selection.

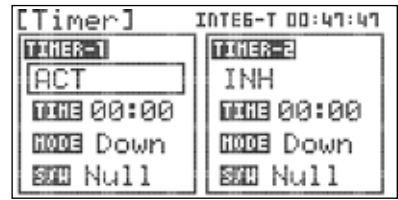

4. Scroll to highlight "TIME" and press the jog dial to activate the menu.

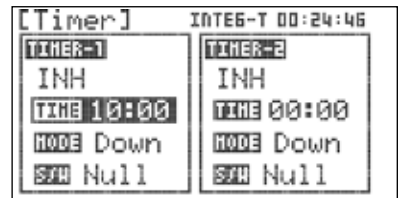

5. Press the jog dial again to activate the minute's field.
6. Scroll to select the desired start value for minutes on Timer-1 and press the jog dial to confirm your selection.

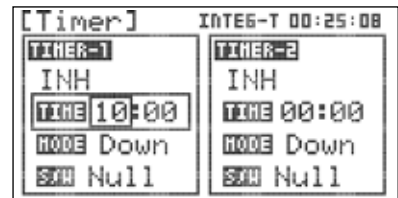

7. Scroll to highlight the seconds field and press the jog dial to activate the menu.
8. Scroll to select the desired start value for seconds on start Timer-1 and press the jog dial to confirm your selection.
9. Press the Back button to return to the timer menu.

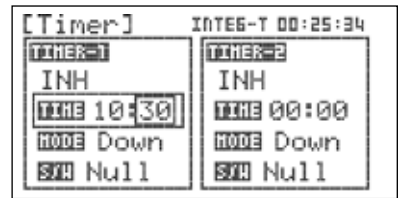

10. Scroll to highlight "MODE" and press the jog dial to activate the menu.
11. Scroll to select "UP" or "Down" and press the jog dial to confirm your selection.

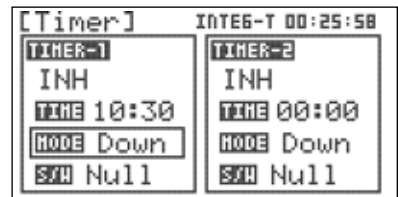

12. Scroll to highlight "S/W" and press the jog dial to activate the menu.



13. Press the jog dial again to activate the switch selection sub-menu.

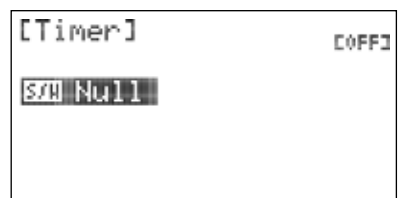

Timers cont.

14. Scroll to select the desired activation switch for the timer.

Press the jog dial to confirm your selection.

a. Selecting "NULL" will cause the timer to be inactive.

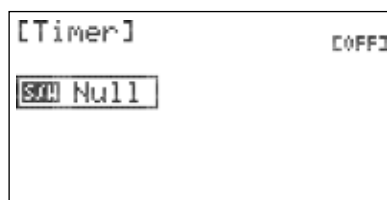

b. If you selected a switch, the switch position menu will appear.

- Scroll to highlight the switch position(s) that you will use to activate the timer.

- Press the jog dial to confirm your selection.

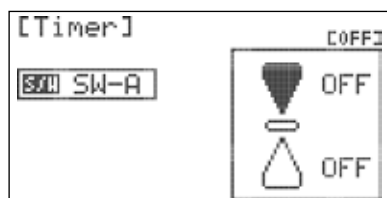

- Scroll to select "ON" and press the jog dial to confirm your selection. If you toggle the selected switch, the field in the top right corner of the screen will indicate if the mix is on or off.

- Press the back button to return to the programmable mix sub-menu.

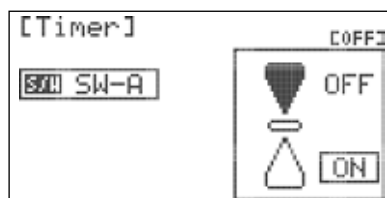

c. If you selected "THR", the throttle position menu will appear.

- Scroll to highlight the top "OFF" field and press the jog dial to confirm your selection.

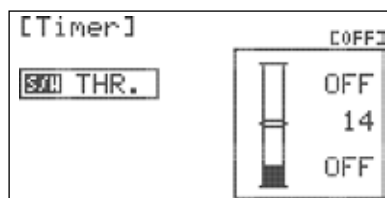

- Scroll to select "ON" and press the jog dial to confirm your selection.

- Scroll to highlight the middle field and press the jog dial to activate the menu.

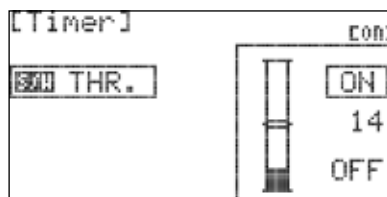

- Move the throttle stick to the position where you want the timer to turn on. We suggest a position just above idle. Note the double line on the screen moves in conjunction with the throttle stick position.

- Scroll to raise the bar on the screen to the double line. Press the jog dial to confirm your selection. The timer will run when the throttle is at or above this setting. It will pause when the throttle is below this setting. If you cycle the throttle position, the field in the top right corner of the screen will indicate when the timer turns on and off.

- Press the back button to return to the timer sub-menu.

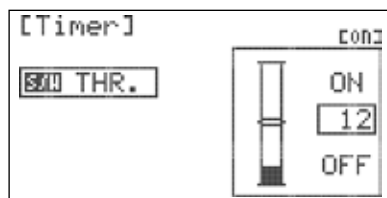

Timers cont.

To reset a timer:

1. From the home screen, scroll to highlight a timer and press the jog dial once to enter the timer menu.
2. Scroll to highlight "TIME" and press the jog dial to activate the menu.
3. Press the back button twice to return to the home screen.

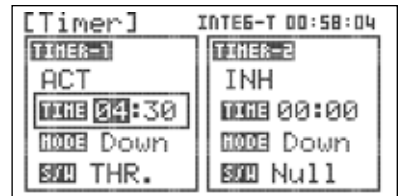
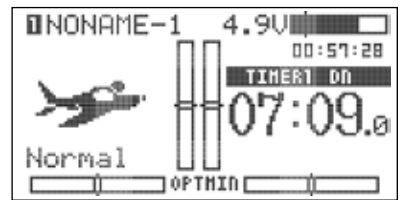

To reset the integrated timer:

1. From the home screen, scroll to highlight a timer and press the jog dial once to enter the timer menu.
2. Scroll to highlight "INTEG-T" and press the jog dial to activate the menu.
3. Press and hold the jog dial until the timer resets to "00:00:00".
4. Press the back button twice to return to the home screen.

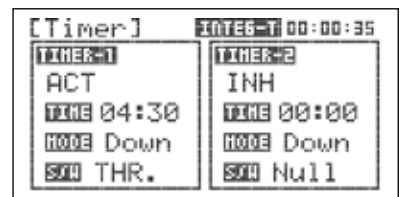
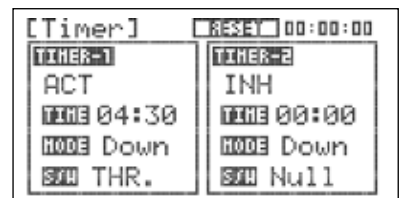

Servo Monitors

The Monitor function will display a graphic representation of all seven channels as they are manipulated with the Flash 7's controls. There are also channel cycling and neutralization functions.

1. From the model menu, scroll to highlight "MONITOR" and press the jog dial once to enter the monitor menu.
2. Manipulate the control inputs (indicating dual-rate switches) and observe the bar graphs indicate the movement for each channel. This screen is useful to verify that each channel is configured with the intended end points and dual rates.

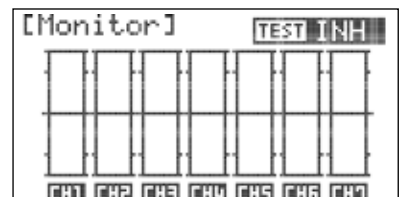
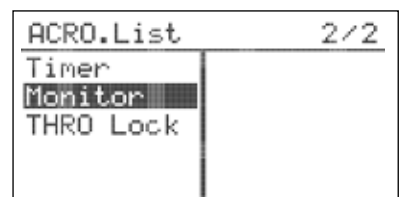

Warning

If you are configuring an electric-powered model, remove the propeller(s) or secure the aircraft before performing the next steps. The test functions will cause an active Electronic Speed Control to drive the motor(s) at varying power levels, including full throttle. An unsecured model can cause substantial bodily injury and/or property damage. Also be mindful of models with retractable landing gear or similar functions that require special attention.

Servo Monitors cont.

3. Press the jog dial to activate the test menu.
4. Scroll to highlight "Move" and press the jog dial to confirm your selection.
5. Observe as the transmitter cycles the designated range of travel for every channel that has been assigned a control input.
6. The cycle test can be halted by either selecting another option in the test menu or pressing the back button to return to the model function menu.
7. Scroll to highlight "Neu" (neutral) and press the jog dial to confirm your selection.

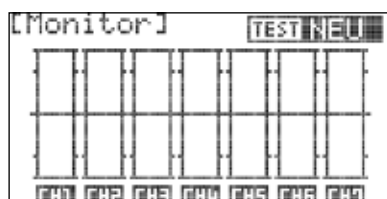
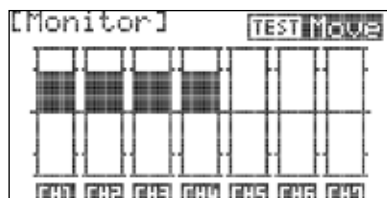
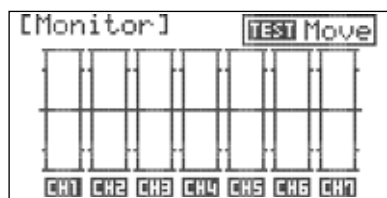

8. Observe that all channels with assigned control inputs have been set to their neutral position (including all trim or sub-trim settings). This screen is useful to position the servos when setting pushrod lengths for control surfaces.
9. The neutral setting can be halted by either selecting another option in the test menu or pressing the back button to return to the model function menu.

Throttle Lock

The Flash 7 features a "throttle lock" function that can be activated when the transmitter is transmitting a signal. We encourage you to use the throttle lock feature as a safety precaution against "accidental throttle application".

1. To turn the throttle lock on, highlight "THRO Lock" from the model setup menu and press the jog dial to enter the setup screen.
2. To select which switch will be used for the throttle lock press the jog dial to enter the switch selection menu.
3. Scroll to select a switch used to activate the throttle lock function. Press the jog dial to confirm your selection.
 - If you choose the "NULL" option, the function will remain inactive at all times for this model.
 - If you choose a switch:
 - The switch position menu will appear. Scroll to highlight the switch position that you will use to enable the function. Press the jog dial to confirm your selection.
 - Scroll to select "ON" and press the jog dial to confirm your selection. If you toggle the selected switch, the field in the top right corner of the screen will indicate when the mix is active.
4. Press the back button twice to return to the Model menu.

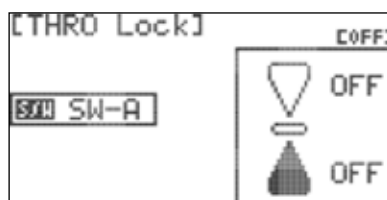
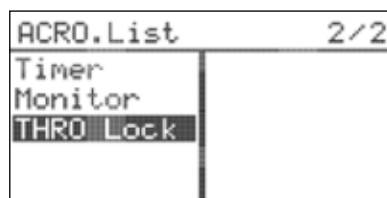

Acro and Glider Programming Menu

When the active model is configured as a fixed-wing (ACRO or GLID) model type, the Model Function menu contains programming options which are useful for fixed-wing aircraft. This section describes the features and programming steps for the ACRO and GLID model function menus.



If you have not already programmed a model with the preceding quick start guide, we encourage you to do so before tackling the model programming section of the manual.

From the Model Function menu, you can program the following fixed-wing-specific functions:

- ***FLT.COND:** Configure specific control settings for different phases of flight.
- AIL DIFF:** Configure aileron servos to move further upwards than down.
- ELEVON MIX:** Specify independent pitch and roll control throws for aircraft with elevons.
- V-TAIL MIX:** Specify independent pitch and yaw control throws for aircraft with a V-tail.
- AILEVATOR:** Specify independent pitch and roll control throws for aircraft with ailevators (also called "tailerons").
- AIL>RUDD:** User-adjustable mix that defines rudder movement with aileron control inputs.
- ELEV>CAMB:** Alter wing control surfaces with elevator inputs.
- Camber Mix (GLID only):** Adjust wing control surfaces with switch movements.
- ***FLAP CON:** Mix elevator throw with flap movement.
- OFFSET:** Fine tune aileron, elevator, and flap positions.
- B-fly (GLID only):** Configure wing control surfaces to act as an air brake (also known as "crow").
- GYRO:** Specify gyro on/off and sensitivity settings.
- THRO CUT (ACRO only):** Configure a kill switch for glow/gas motors.
- T.CURVE (ACRO only):** Specify non-linear throttle response.



ACRO Model Function Menu Page 1



ACRO Model Function Menu Page 2



Glider Model Function Menu Page 1



Glider Model Function Menu Page 2

Working with the Acro/Glid Model Function Menu

1. Turn on transmitter. When prompted to transmit, select "NO".
2. Verify that the active model is an ACRO or GLID model type.
3. To access the model function menu, press and hold the jog dial.
4. The menu options shown reflect the parameters defined for the active model in the model type menu (Model Type, Wing and Tail). ACRO and GLID-specific items are integrated in the menu with the options that are common to all model types.

Flight Conditions

The Flash 7 allows you to program up to four flight conditions. This powerful feature lets you define customized trim values and mix settings for different phases of flight.

The flight conditions for fixed wing aircraft are:

ACRO	GLID
1. Normal	1. Normal
2. COND-2	2. Speed
3. COND-3	3. Thermal
4. COND-4	4. Launch

The following features support flight condition programming in ACRO or GLID mode:

Aileron > Rudder Mix
 Elevator > Camber Mix
 Camber Mix (GLID only)
 Gyro

1. From the model menu, rotate the jog dial to highlight "F.COND" and press the jog dial once to enter the flight conditions menu.
2. Scroll to the flight condition to be configured and press the jog dial to confirm your selection.
3. Press the jog dial again to activate the switch selection menu (not applicable in "Normal" flight condition).

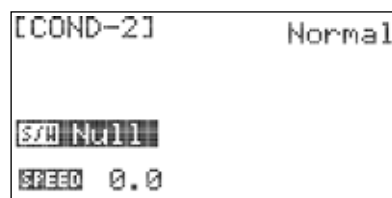
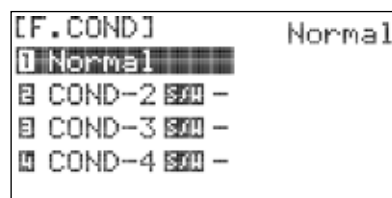

4. Scroll to select the switch that you will use to activate this flight condition and press the jog dial to confirm your selection.
 - a. If "NULL" is selected, the flight condition will be inactive.
 - b. If you selected a switch, the switch position menu will appear.
 - Scroll to highlight the switch position that you will use to enable the flight condition. Press the jog dial to confirm your selection.
 - Scroll to select the "ON" position and press the jog dial to confirm your selection. If you toggle the selected switch, the field in the top right corner of the screen will indicate which flight condition is active.

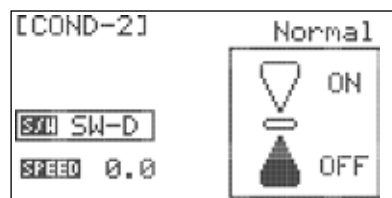

Flight Conditions cont.



Tip

If more than one flight condition is concurrently enabled, the condition with the highest number (per the table shown above) will be active. The field just below the model icon on the Home screen indicates the active flight condition.

- Press the back button twice to return to the flight conditions menu.

5. Scroll to highlight the "SPEED" field and press the jog dial to activate the menu.

6. Scroll to define the amount of time (0.0 to 10.0 seconds) to transition the settings when this flight condition is enabled. Press the jog dial to confirm your selection. This feature can be utilized to prevent sudden control surface movements when switching between flight conditions.

7. Press the back button to return to the flight conditions menu and repeat steps 2-6 to define further flight conditions.

8. Press the back button twice to return to the model function menu.

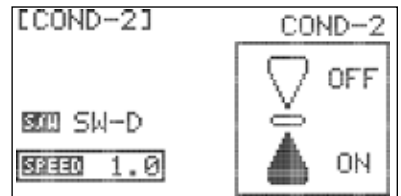

Aileron Differentials

The Aileron Differential function allows you to program greater upward aileron movement than downward movement on models with more than one wing servo. This setup is commonly used to correct airplanes that tend to yaw in the opposite direction of a roll (adverse yaw). You may also wish to configure aileron-rudder mixing in this situation.

1. From the model menu, rotate the jog dial to highlight "AIL DIFF" and press the jog dial once to enter the aileron differential menu.

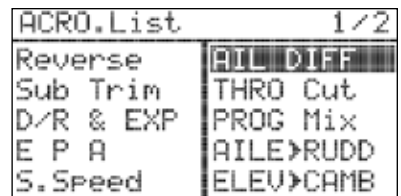

2. Scroll to the "RATE" field and press the jog dial to activate the menu.

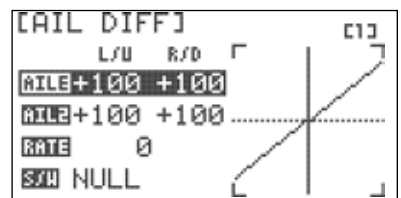

3. Scroll to input the desired rate value. This value represents the difference between 100% downward travel and the adjusted travel. A rate value of 50 is typically a good starting point. Note that the travel values displayed in the "AILE" and AIL2" fields reflect changes to the rate value.

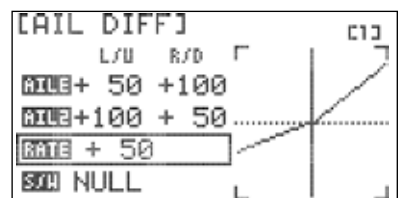

Note

You can also enter the timer menu directly from the home screen. Scroll to highlight a timer on the screen and press the jog dial.

Aileron Differentials cont.

4. Scroll to the "S/W" field and press the jog dial to activate the menu.
5. Scroll to select a switch to control aileron differential settings. Press the jog dial to confirm your selection. If you choose the "NULL" option, the current settings will remain active at all times for this model. If you choose a switch, repeat steps 2-4 to define the settings for each switch position.

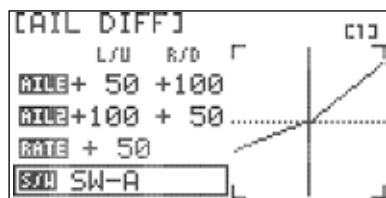
**Note**

You can customize individual travel values in the "AILE" and "AIL2" fields by scrolling to those fields and activating the sub-menus.

6. Press the back button to return to the model function menu.

Elevon Mixing

Flying wing aircraft are most often set up using elevon control surfaces. The Flash 7 mixes the aileron and elevator functions to provide this configuration with just one flight control surface per wing panel.

**Tip**

It is not necessary to access or change this menu to fly an elevon-equipped aircraft. The default values are 100% in all directions.

1. From the model menu, rotate the jog dial to highlight "Elevon Mix" and press the jog dial once to enter the elevon mix menu.



2. Scroll to the top "AILE" field and press the jog dial to activate the menu.

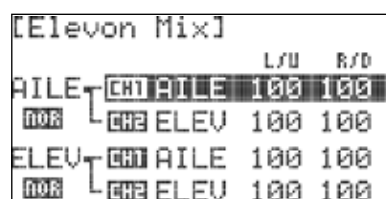

3. Scroll to highlight the "L/U" (left/up) field and press the jog dial to activate the menu.

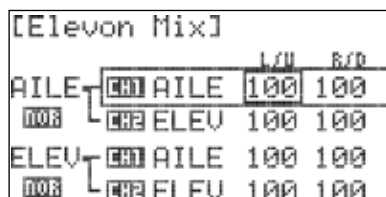

4. Rotate the jog dial to increase (clockwise) or decrease (counter-clockwise) the desired endpoint for the servo attached to the "AILE" receiver slot. This value regards the servo travel when a left roll command is given. Press the jog dial to confirm your input.

5. Scroll to highlight the "R/D" (right/down) field and press the jog dial to activate the menu.

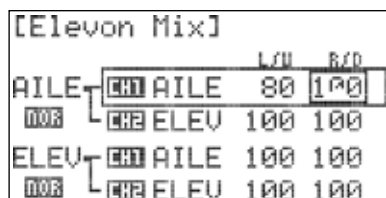

6. Rotate the jog dial to increase (clockwise) or decrease (counter-clockwise) the desired servo endpoint when a right roll command is given. Press the jog dial to confirm your input.

Elevon Mixing cont.

7. Press the back button to return to the elevon mix menu.
8. Scroll to the top "ELEV" field and press the jog dial to activate the menu.

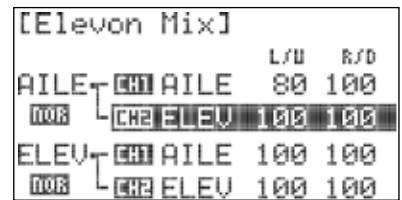

9. Scroll to highlight the "L/U" (left/up) field and press the jog dial to activate the menu.
10. Rotate the jog dial to increase (clockwise) or decrease (counter-clockwise) the desired endpoint for the servo attached to the "ELEV" receiver slot. This value regards the servo travel when a left roll command is given. Press the jog dial to confirm your input.

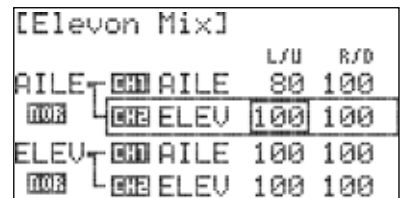

11. Scroll to highlight the "R/D" (right/down) field and press the jog dial to activate the menu.
12. Rotate the jog dial to increase (clockwise) or decrease (counter-clockwise) the desired servo endpoint when a right roll command is given. Press the jog dial to confirm your input.
13. Press the back button to return to the elevon mix menu.

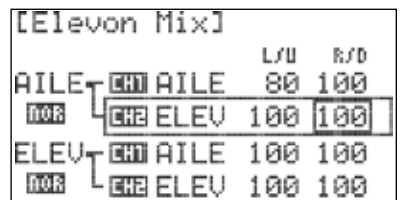

14. Repeat steps 2-13 using the lower "AILE" and "ELEV" fields to set the servo endpoints when pitch (elevator) commands are given.

15. If aileron or elevator functions operate in the incorrect direction, highlight the direction field ("nor") under the function name and press the jog dial to activate the menu.
16. Scroll to select "rev" and press the jog dial to confirm your selection. Verify that the control surfaces now move in the correct direction.

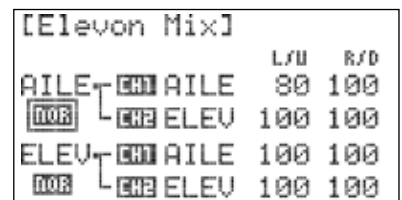

17. Push the "Back" button twice to return to the model function menu.

V-Tail Mixing

Aircraft with a V-tail configuration can use this function to specify the limits of travel for both tail control surface servos.

1. From the model menu, rotate the jog dial to highlight "V.Tail Mix" and press the jog dial once to enter the V-tail mix menu.

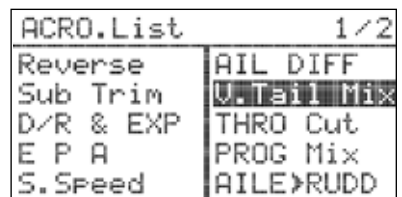

2. Scroll to the top "ELEV" field and press the jog dial to activate the menu.

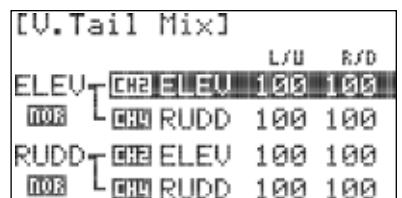

V-Tail Mixing cont.

3. Scroll to highlight the "L/U" (left/up) field and press the jog dial to activate the menu.
4. Rotate the jog dial to increase (clockwise) or decrease (counter-clockwise) the desired endpoint for the servo attached to the "ELEV" receiver slot. This value regards the servo travel when a pitch up command is given. Press the jog dial to confirm your input.
5. Scroll to highlight the "R/D" (right/down) field and press the jog dial to activate the menu.
6. Rotate the jog dial to increase (clockwise) or decrease (counter-clockwise) the desired servo endpoint when a pitch down command is given. Press the jog dial to confirm your input.
7. Press the back button to return to the V-tail menu.
8. Scroll to the top "RUDD" field and press the jog dial to activate the menu.
9. Scroll to highlight the "L/U" (left/up) field and press the jog dial to activate the menu.
10. Rotate the jog dial to increase (clockwise) or decrease (counter-clockwise) the desired endpoint for the servo attached to the "RUDD" receiver slot. This value regards the servo travel when a pitch up command is given. Press the jog dial to confirm your input.
11. Scroll to highlight the "R/D" (right/down) field and press the jog dial to activate the menu.
12. Rotate the jog dial to increase (clockwise) or decrease (counter-clockwise) the desired servo endpoint when a pitch down command is given. Press the jog dial to confirm your input.
13. Press the back button the return to the V-tail Mix menu.
14. Repeat steps 2-13 using the lower "ELEV" and "RUDD" fields to set servo endpoints when yaw (rudder) commands are given.
15. If elevator and/or rudder functions operate in the incorrect direction, highlight the direction field ("nor") under the reversed function and press the jog dial to activate the menu.
16. Scroll to select "rev" and press the jog dial to confirm your selection. Verify that the control surfaces now move in the correct direction.
17. Push the back button twice to return to the model function menu.

[V.Tail Mix]				L/U	R/D
ELEV	CH2	ELEV	100	100	
nor	CH4	RUDD	100	100	
RUDD	CH2	ELEV	100	100	
nor	CH4	RUDD	100	100	

[V.Tail Mix]				L/U	R/D
ELEV	CH2	ELEV	100	100	
nor	CH4	RUDD	100	100	
RUDD	CH2	ELEV	100	100	
nor	CH4	RUDD	100	100	

[V.Tail Mix]				L/U	R/D
ELEV	CH2	ELEV	100	100	
nor	CH4	RUDD	100	100	
RUDD	CH2	ELEV	100	100	
nor	CH4	RUDD	100	100	

[V.Tail Mix]				L/U	R/D
ELEV	CH2	ELEV	100	100	
nor	CH4	RUDD	100	100	
RUDD	CH2	ELEV	100	100	
nor	CH4	RUDD	100	100	

[V.Tail Mix]				L/U	R/D
ELEV	CH2	ELEV	100	100	
nor	CH4	RUDD	100	100	
RUDD	CH2	ELEV	100	100	
nor	CH4	RUDD	100	100	

[V.Tail Mix]				L/U	R/D
ELEV	CH2	ELEV	100	100	
nor	CH4	RUDD	100	100	
RUDD	CH2	ELEV	100	100	
rev	CH4	RUDD	100	100	

Ailevator Mixing

The Ailevator feature allows the configuration of a two-servo or “split” elevator setup. It also features an “aileron to split elevator” mix which allows the elevators to provide roll control. This feature, also called “tailerons”, is commonly used on jet models.

1. From the model menu, rotate the jog dial to highlight “AILEVATOR” and press the jog dial once to enter the ailevator mix menu.



2. Scroll to the top “ELEV” field and press the jog dial to activate the menu.

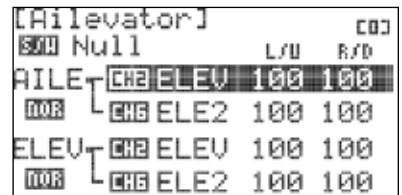

3. Scroll to highlight the “L/U” (left/up) field and press the jog dial to activate the menu.

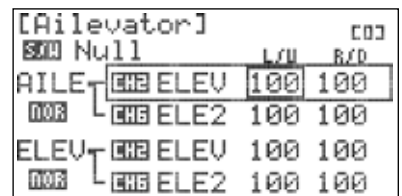

4. Rotate the jog dial to increase (clockwise) or decrease (counter-clockwise) the desired endpoint for the servo attached to the “ELEV” receiver slot. This value regards the servo travel when a left roll command is given. Press the jog dial to confirm your input.

5. Scroll to highlight the “R/D” (right/down) field and press the jog dial to activate the menu.

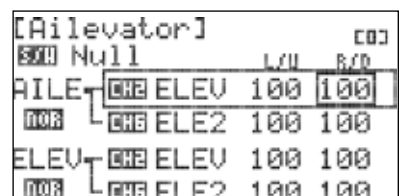

6. Rotate the jog dial to increase (clockwise) or decrease (counter-clockwise) the desired servo endpoint when a right roll command is given. Press the jog dial to confirm your input.
7. Press the back button to return to the ailevator menu.

8. Scroll to the top “ELEV2” field and press the jog dial to activate the menu.

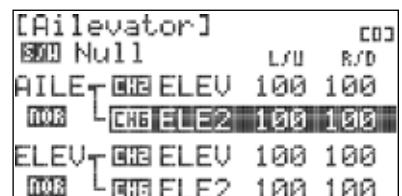

9. Scroll to highlight the “L/U” (left/up) field and press the jog dial to activate the menu.

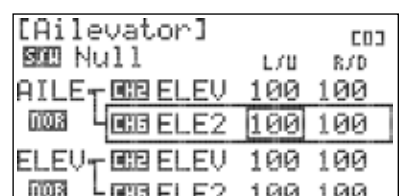

10. Rotate the jog dial to increase (clockwise) or decrease (counter-clockwise) the desired endpoint for the servo attached to the “RUDD” receiver slot. This value regards the servo travel when a left roll command is given. Press the jog dial to confirm your input.

Ailevator Mixing cont.

11. Scroll to highlight the "R/D" (right/down) field and press the jog dial to activate the menu.
12. Rotate the jog dial to increase (clockwise) or decrease (counter-clockwise) the desired servo endpoint when a right roll command is given. Press the jog dial to confirm your input.
13. Press the back button to return to the Ailevator Mix menu.
14. Repeat steps 2-13 using the lower "ELEV" and "ELE2" fields to set servo endpoints when pitch (elevator) commands are given.
15. If elevator and/or aileron functions operate in the incorrect direction, highlight the direction field ("nor") under the reversed function and press the jog dial to activate the menu.
16. Push the back button twice to return to the model function menu.

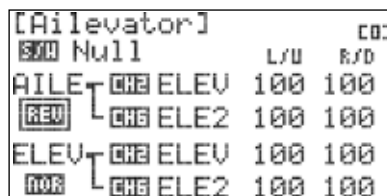
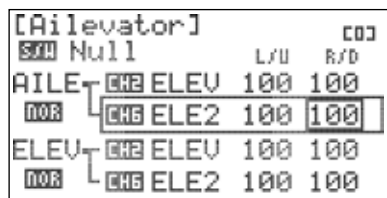
**Aileron to Rudder Mixing**

Many models (especially large-scale aircraft) fly through turns more smoothly when aileron and rudder commands are used simultaneously. The Aileron-Rudder mix will automatically apply rudder input when aileron commands are given.

To configure an aileron-rudder mix:

1. From the model menu, rotate the jog dial to highlight "AILE>RUDD" and press the jog dial once to enter the activation menu.
2. Press the jog dial again to activate the menu.
3. Rotate the jog dial to select "ACT" (activate), then press the jog dial to confirm your selection and activate the aileron-rudder mix menu.
4. Scroll to highlight the "RATE" field. Press the jog dial to activate the menu.
5. Scroll to highlight the "L/U" (left/up) field and press the jog dial to activate the menu.
6. Rotate the jog dial to increase (clockwise) or decrease (counter-clockwise) the desired rudder travel when a left roll command is given. Press the jog dial to confirm your input.

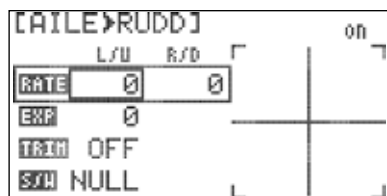
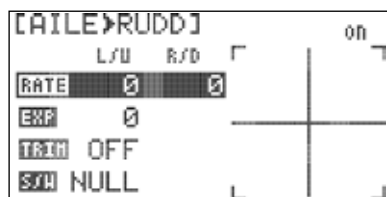
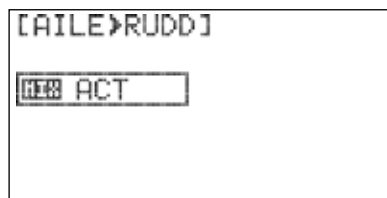
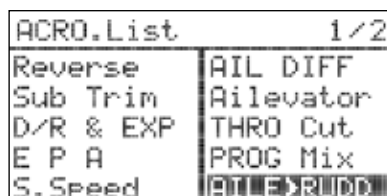

Aileron to Rudder Mixing cont.

7. Scroll to highlight the "R/D" (right/down) field and press the jog dial to activate the menu.
8. Rotate the jog dial to increase (clockwise) or decrease (counter-clockwise) the desired rudder travel when a right roll command is given. Press the jog dial to confirm your input.

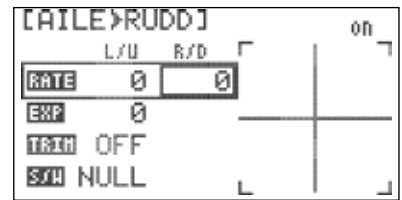

9. Scroll to highlight the "EXP" field and press the jog dial to activate the selection.
10. Rotate the jog dial to input the desired exponential travel of the rudder when reacting to this mix. The setting does not affect exponential travel when yaw commands are given.

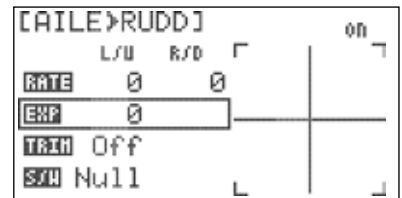

11. Scroll to highlight the "TRIM" field and press the jog dial to activate the menu.
12. Scroll to select "ON" or "OFF" and press the jog dial to confirm your selection. When "ON" is selected, the mix reacts to trim adjustments of the ailerons. Otherwise, the mix ignores aileron trim changes.

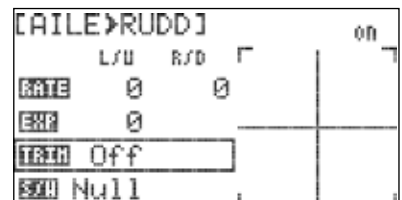

13. Scroll to the "S/W" field and press the jog dial twice to activate the menu.

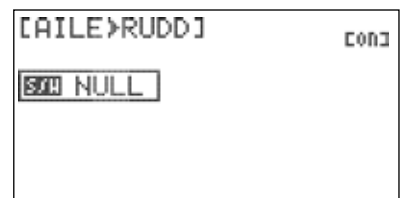

14. Scroll to select a switch to activate the mix. Press the jog dial to confirm your selection.
 - a. If you choose the "NULL" option, the mix will remain active at all times for this model.

b. If you choose a switch:

- The switch position menu will appear. Scroll to highlight the switch position that you will use to enable the mix. Press the jog dial to confirm your selection.

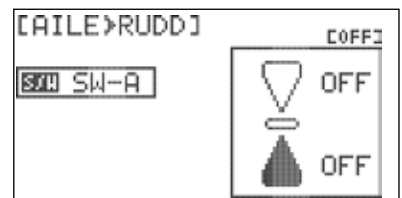

- Scroll to select "ON" and press the jog dial to confirm your selection. If you toggle the selected switch, the field in the top right corner of the screen will indicate when the mix is active.



Aileron to Rudder Mixing cont.

c. If you choose "Cond" (Flight Condition):

- The upper right field of the menu displays which flight condition is currently active and will be programmed.
- Scroll to the Flight Condition field and press the jog dial to activate the menu.

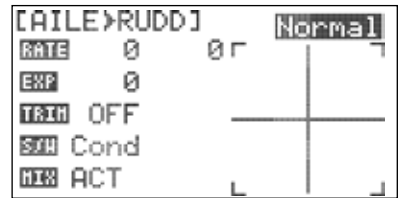

- Choose the desired flight condition and press the jog dial to confirm your selection.



Tip

You may also select a flight condition in this menu by activating the desired flight condition.

- Repeat steps 4-12 to define the settings for each flight condition.

15. Press the back button to return to the model function menu.

To disable the aileron-rudder mix:

1. Scroll to highlight the "MIX" field in the aileron-rudder mix menu and press the jog dial to activate the menu.
2. Select "INH" (inhibit) and press the jog dial to confirm your selection.
3. Press the back button to return to the model function menu.

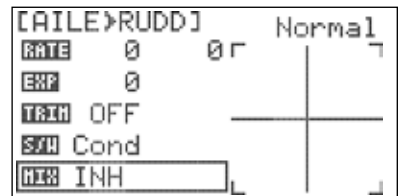
**Elevator to Camber Mixing**

The Elevator-to-Camber Mix allows the model to drop and raise the trailing edge of the wing control surfaces in conjunction with elevator inputs. This function is not valid for the "1AILE" or "ELEVON" wing types unless flaps are also present. If using a "1AILE + 1FLAP", "1AILE + 2FLAP", "ELEVON + 1FLP", or "ELEVON + 2FLP" wing type, do not configure any settings for the "AILE" function. Configure only flap servo movements.

To configure an elevator-to-camber mix:

1. From the model menu, rotate the jog dial to highlight "ELEV>CAMB" and press the jog dial once to enter the activation menu.
2. Press the jog dial again to activate the menu.
3. Rotate the jog dial to select "ACT" (activate), then press the jog dial to confirm your selection and activate the elevator-to-camber mix menu.
4. Scroll to the function field ("AILE" or "FLAP"). If "AILE" is not the current function, press the jog dial to activate the menu. Otherwise, skip to step 7.
5. Scroll to select "AILE" and press the jog dial to confirm your selection.

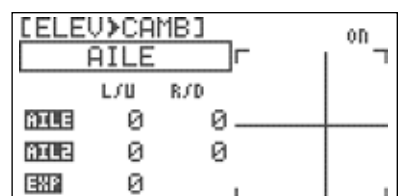
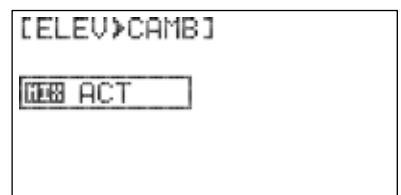

Elevator to Camber Mixing cont.

7. Scroll to the top row of the value table ("AILE") and press the jog dial to activate the menu.

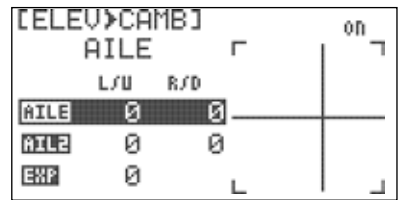

8. Scroll to highlight the "L/U" (left/up) field and press the jog dial to activate the menu.

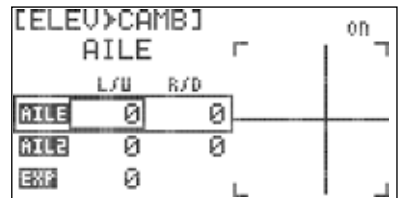

9. Rotate the jog dial to set the desired endpoint for the servo attached to the "AILE" receiver slot. This value regards the servo travel when a pitch up command is given. This setting does not affect the travel of the servo when roll commands are given. Press the jog dial to confirm your input.

10. Scroll to highlight the "R/D" (right/down) field and press the jog dial to activate the menu.

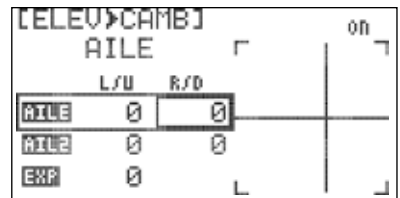

11. Rotate the jog dial to set the desired servo endpoint for the when a pitch down command is given.

12. Repeat steps 6-10 to set the endpoints for the servo attached to the "AILE2" receiver slot (second row of the value table). As with the previous settings, the values input here do not affect the servo travel when roll commands are given.

13. Scroll to highlight the "EXP" field and press the jog dial to activate the selection.

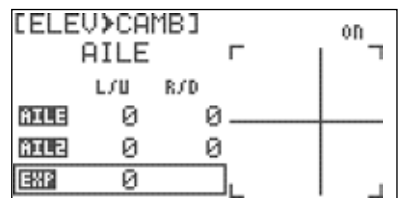

14. Rotate the jog dial to input the desired exponential travel of the aileron servos when reacting to this mix. The setting does not affect exponential travel of the servos when roll commands are given.

15. Scroll to highlight the "TRIM" field and press the jog dial to activate the menu.

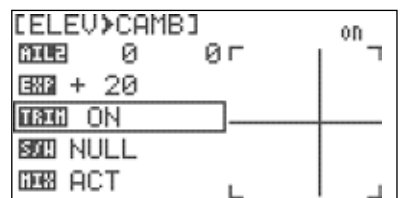

16. Scroll to select "ON" or "OFF" and press the jog dial to confirm your selection. When "ON" is selected, the mix reacts to trim adjustments of the elevator. Otherwise, the mix ignores elevator trim changes.

17. If the model is equipped with flaps, scroll to the function field ("AILE" or "FLAP") and press the jog dial to activate the menu. Otherwise, skip to step 19.

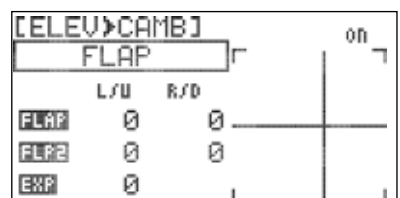

Elevator to Camber Mixing cont.

18. Scroll to select "FLAP" and press the jog dial to confirm your selection.

19. Repeat steps 5-15 to configure the flap movements for this mix. If using only one flap servo, configure only the "FLAP" row of the value table. If using two flap servos, configure both rows of the value table.

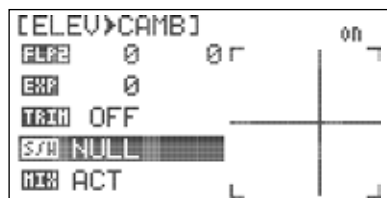

20. Scroll to the "S/W" field and press the jog dial twice to activate the menu.

21. Scroll to select a switch to activate the mix. Press the jog dial to confirm your selection.



a. If you choose the "NULL" option, the mix will remain active at all times for this model.

b. If you choose a switch:

- The switch position menu will appear. Scroll to highlight the switch position that you will use to enable the mix. Press the jog dial to confirm your selection



- Scroll to select "ON" and press the jog dial to confirm your selection. If you toggle the selected switch, the field in the top right corner of the screen will indicate when the mix is active.



c. If you choose "Cond" (Flight Condition):

-The upper right field of the menu displays which flight condition is currently active and will be programmed.



- Scroll to the Flight Condition field and press the jog dial to activate the menu.

- Choose the desired flight condition and press the jog dial to confirm your selection.

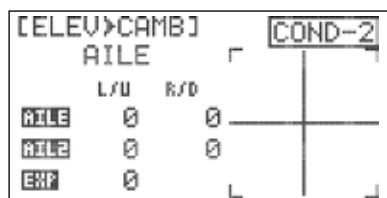

Tip

You may also select a flight condition in this menu by activating the desired flight condition.

- Repeat steps 4-18 to define the settings for each flight condition.

Elevator to Camber Mixing cont.

22. Press the back button to return to the model function menu.

To disable the elevator-to-camber mix:

1. Scroll to highlight the "MIX" field in the elevator-camber mix menu and press the jog dial to activate the menu.
2. Select "INH" (inhibit) and press the jog dial to confirm your selection.
3. Press the back button to return to the model function menu.

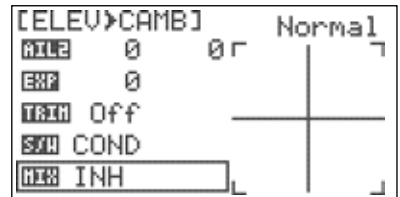

Camber Mixing (GLID Only)

The Camber Mix feature allows you to define the camber of the wing airfoil by raising or lowering the wing control surfaces in unison. You may also adjust the elevator neutral position in each setting to maintain proper pitch trim.

To configure the camber mix:

1. From the Model menu, rotate the jog dial to highlight "Camber Mix" and press the jog dial once to enter the activation menu.



2. Press the jog dial again to activate the menu.

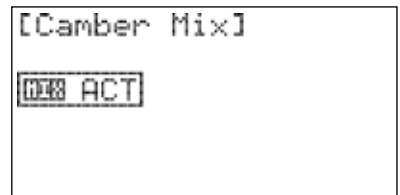

3. Rotate the jog dial to select "ACT" (activate), then press the jog dial to confirm your selection and activate the camber mix menu.

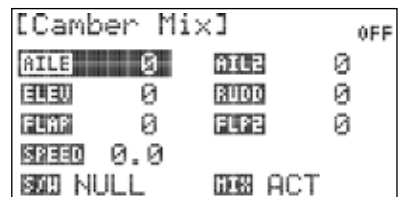

4. Scroll to highlight the "AILE" field and press the jog dial to activate the menu.

5. Rotate the jog dial to input the desired travel for the "AILE" servo when camber is active. Press the jog dial to confirm your input.

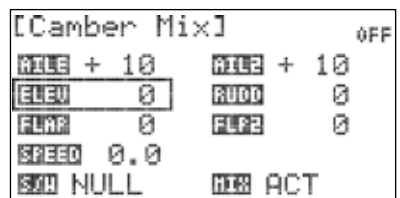

6. If the model has a second aileron servo, repeat step 5 in the "AIL2" field.

7. Scroll to highlight the "ELEV" field and press the jog dial to activate the menu.

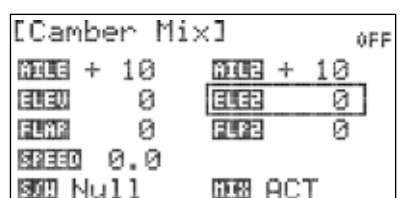

8. Rotate the jog dial to input the desired travel for the "ELEV" servo when camber is active. Press the jog dial to confirm your input.

9. If the model has a second elevator servo, repeat step 8 in the "ELE2" field.

Camber Mixing (GLID Only) cont.

10. Scroll to highlight the "FLAP" field and press the jog dial to activate the menu.
11. Rotate the jog dial to input the desired travel for the "FLAP" servo when camber is active. Press the jog dial to confirm your input.
12. If the model has a second flap servo, repeat step 11 in the "FLP2" field.



13. Scroll to highlight the "SPEED" field and press the jog dial to activate the menu.
14. Scroll to define the amount of time (0.0 to 10.0 seconds) for the camber settings to fully deploy. Press the jog dial to confirm your selection.

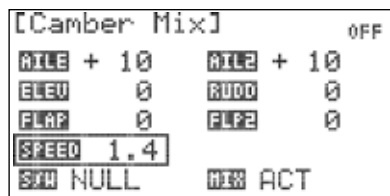

15. Scroll to the "S/W" field and press the jog dial twice to activate the menu.

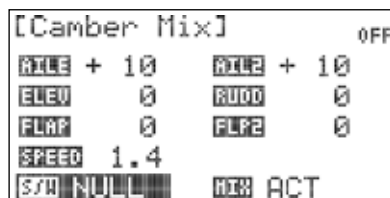

16. Scroll to select a switch to activate the camber mix. Press the jog dial to confirm your selection.
 - a. If you choose the "NULL" option, the mix will remain inactive at all times for this model.

b. If you choose a switch:

- The switch position menu will appear. Scroll to highlight the switch position that you will use to enable the mix. Press the jog dial to confirm your selection.

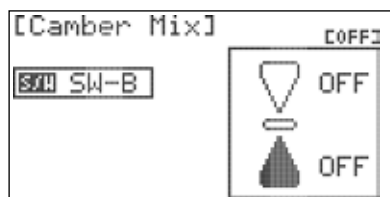

- Scroll to select "ON" and press the jog dial to confirm your selection. If you toggle the selected switch, the field in the top right corner of the screen will indicate when the mix is active.

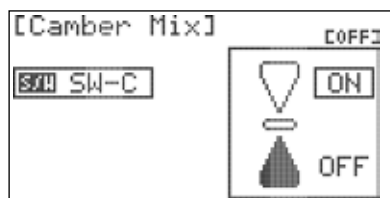

c. If you choose "Cond" (Flight Condition):

- The upper right field of the menu displays which flight condition is currently active and will be programmed.
- Scroll to the Flight Condition field and press the jog dial to activate the menu.
- Choose the desired flight condition and press the jog dial to confirm your selection.

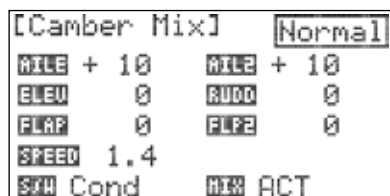

Camber Mixing (GLID Only) cont.



You may also select a flight condition in this menu by activating the desired flight condition.

- Repeat steps 4-18 to define the settings for each flight condition.
17. Press the back button to return to the model function menu.

To disable the elevator-to-camber mix:

1. Scroll to highlight the "MIX" field in the camber mix menu and press the jog dial to activate the menu.
2. Select "INH" (inhibit) and press the jog dial to confirm your selection.
3. Press the back button to return to the model function menu.

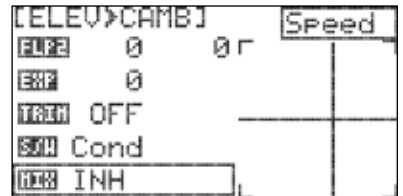

Flap Control

Flap Control is used to mix elevator control with flap movements. This is an effective way of avoiding pitch changes to the aircraft when flaps are deployed.

To configure flap control:

1. From the model menu, rotate the jog dial to highlight "FLAP CON" and press the jog dial once to enter the activation menu.



2. Press the jog dial again to activate the menu.

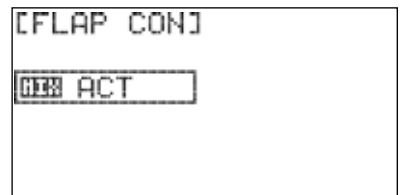

3. Rotate the jog dial to select "ACT" (activate), then press the jog dial to confirm your selection and activate the flap control menu.
4. Highlight the "FLAP" row of the value table and press the jog dial to activate the menu.

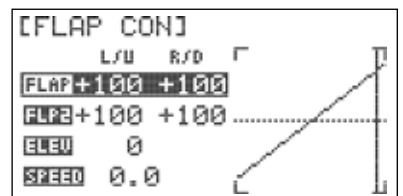

5. Scroll to highlight the "L/U" (left/up) field and press the jog dial to activate the menu.
6. Rotate the jog dial to increase (clockwise) or decrease (counter-clockwise) the desired endpoint for the servo attached to the assigned flap channel. This value defines the end point when the flap is fully retracted. Set this value carefully to avoid any binding of the control linkages. Press the jog dial to confirm your input.

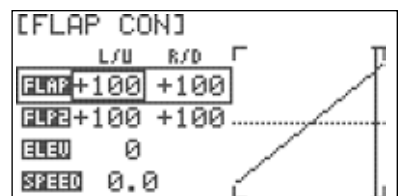

Flap Control

7. Scroll to highlight the "R/D" (right/down) field and press the jog dial to activate the menu.
8. Rotate the jog dial to increase (clockwise) or decrease (counter-clockwise) the desired servo endpoint for when the flap is fully deployed.
9. If the model has a second flap servo, repeat steps 4-8 on the "FLP2" row of the value table.
10. Press the back button to return to the flap control menu.
11. Scroll to highlight the "ELEV" field and press the jog dial to activate the menu.

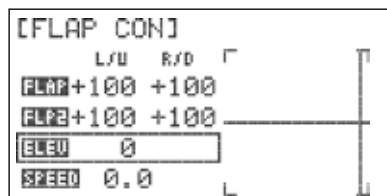
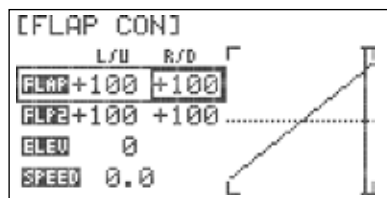
**Tip**

Be sure to have the elevator servo(s) configured properly before performing the next step.

12. Rotate the jog dial to input the desired amount of elevator throw when the flaps are fully deployed. Press the jog dial to confirm your input. Most models require down elevator with flap deployment, which equates to positive values in this menu.
13. Scroll to highlight the "SPEED" field and press the jog dial to activate the menu.
14. Scroll to define the amount of time (0.0 to 10.0 seconds) for the flaps and elevator mix to fully deploy. Press the jog dial to confirm your selection.
15. Press the back button to return to the model function menu.

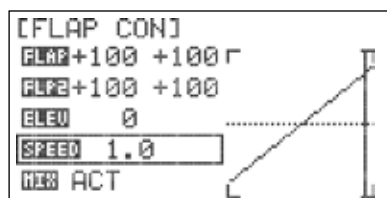

To disable flap control:

1. Scroll to highlight the "MIX" field in the flap control menu and press the jog dial to activate the menu. 2. Select "INH" (inhibit) and press the jog dial to confirm your selection. Goes with above screen shot.
3. Press the back button to return to the model function menu.

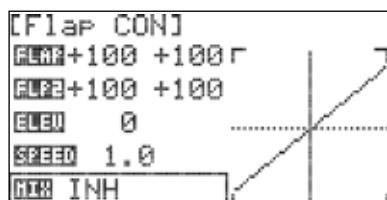

Offset

The Offset feature provides a convenient method to fine tune the neutral positions of the aileron, flap, and elevator servo.

To configure offset:

1. From the model menu, rotate the jog dial to highlight "Offset" and press the jog dial once to enter the activation menu.



Offset cont.

2. Press the jog dial again to activate the menu.
3. Rotate the jog dial to select "ACT" (activate), then press the jog dial to confirm your selection and activate the offset menu.

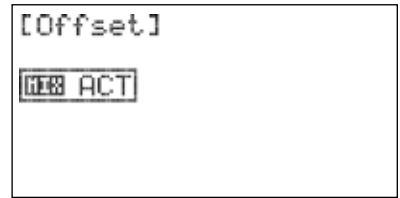

4. Scroll to highlight the "AILE" field and press the jog dial to activate the menu.
5. Rotate the jog dial to input the desired travel for the "AILE" servo when Offset is active. Press the jog dial to confirm your input.
6. If the model has a second aileron servo, repeat step 5 in the "AIL2" field.

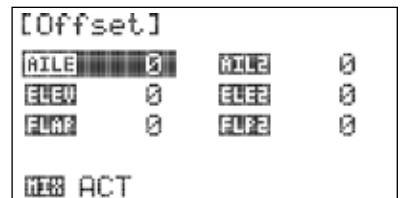

7. Scroll to highlight the "ELEV" field and press the jog dial to activate the menu.
8. Rotate the jog dial to input the desired travel for the "ELEV" servo when Offset is active. Press the jog dial to confirm your input.
9. If the model has a second elevator servo, repeat step 8 in the "ELE2" field.

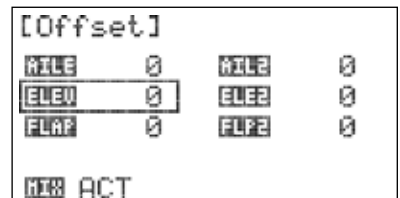

10. Scroll to highlight the "FLAP" field and press the jog dial to activate the menu.
11. Rotate the jog dial to input the desired travel for the "FLAP" servo when Offset is active. Press the jog dial to confirm your input.
12. If the model has a second flap servo, repeat step 11 in the "FLP2" field.
13. Press the back button to return to the model function menu.

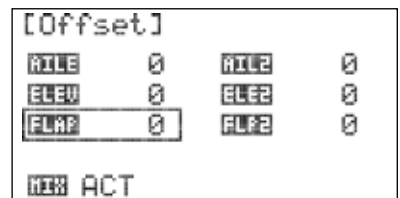

To disable offset:

1. Scroll to highlight the "MIX" field in the offset menu and press the jog dial to activate the menu.
2. Select "INH" (inhibit) and press the jog dial to confirm your selection.
3. Press the back button to return to the model function menu.

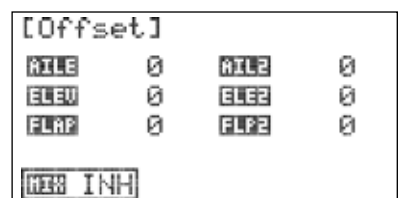

Butterfly Mixing (GLID Only)

B-fly (Butterfly, also called "crow") mixing configures the wing control surfaces to act as an air brake by dropping the flaps and raising the ailerons. You may also program elevator throw to maintain pitch trim. This mix is often used to slow slippery gliders for landing. The mix is usually activated with the linear action of the throttle stick.

Butterfly Mixing (GLID Only) cont.**To configure butterfly:**

- From the model menu, rotate the jog dial to highlight "B-Fly" and press the jog dial once to enter the activation menu.
- Press the jog dial again to activate the menu.
- Rotate the jog dial to select "ACT" (activate), then press the jog dial to confirm your selection and activate the butterfly menu.
- Scroll to highlight the "AILE" field and press the jog dial to activate the menu.
- Rotate the jog dial to input the desired travel for the "AILE" servo when Butterfly is active. Press the jog dial to confirm your input.
- If the model has a second aileron servo, repeat step 5 in the "AIL2" field.
- Scroll to highlight the "ELEV" field and press the jog dial to activate the menu.
- Rotate the jog dial to input the desired travel for the "ELEV" servo when Butterfly is active. Press the jog dial to confirm your input.
- If the model has a second elevator servo, repeat step 8 in the "ELE2" field.
- Scroll to highlight the "FLAP" field and press the jog dial to activate the menu.
- Rotate the jog dial to input the desired travel for the "FLAP" servo when Butterfly is active. Press the jog dial to confirm your input.
- If the model has a second flap servo, repeat step 11 in the "FLP2" field.
- Press the back button to return to the butterfly menu.
- Scroll to highlight the "SPEED" field and press the jog dial to activate the menu.
- Scroll to define the amount of time (0.0 to 10.0 seconds) for the butterfly mix to fully deploy. Press the jog dial to confirm your selection.

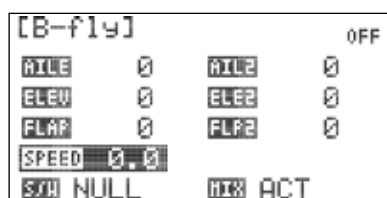
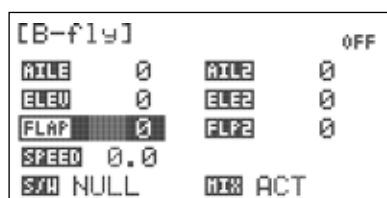
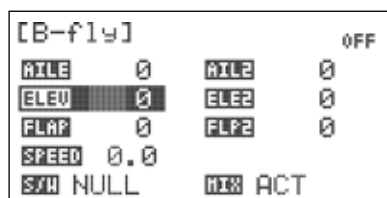
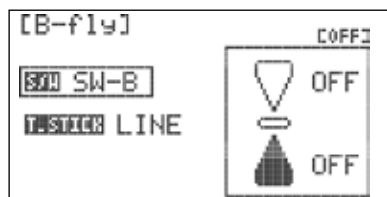
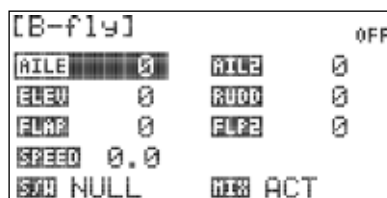
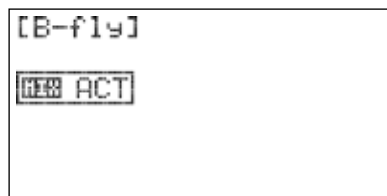

Butterfly Mixing (GLID Only) cont.

16. Scroll to the "S/W" field and press the jog dial twice to activate the menu.

17. Scroll to select a switch to activate the butterfly mix. Press the jog dial to confirm your selection.

a. If you choose the "NULL" option, the butterfly mix will remain inactive at all times for this model.

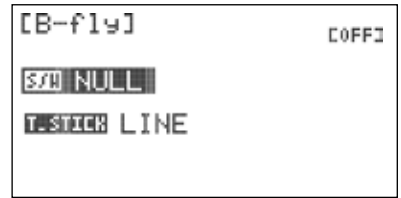

b. If you choose a switch:

- The switch position menu will appear. Scroll to highlight the switch position that you will use to enable the mix. Press the jog dial to confirm your selection.

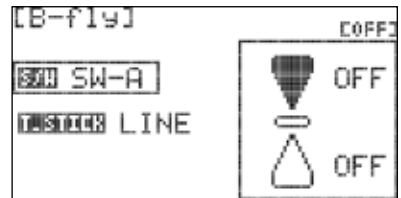

- Scroll to select "ON" and press the jog dial to confirm your selection. If you toggle the selected switch, the field in the top right corner of the screen will indicate when the mix is active.

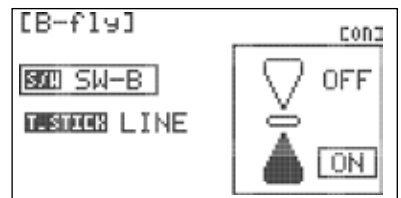

18. Scroll to highlight the "T.STICK" field and press the jog dial to activate the menu.

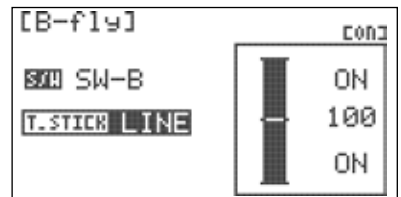

19. Scroll to select the movement type for the throttle stick. Press the jog dial to confirm your selection.

a. If you choose "LINE" (linear) the mix will be applied proportionally to throttle position. For fully linear movement, verify that the throttle position menu shows the mix to be on at both ends of the throttle range, and the middle value is "100".

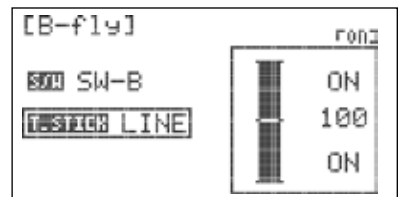

The SPEED value is ignored when linear movement is selected.

b. If you choose "DIV." (divided), the mix will be applied fully when the throttle position crosses a defined threshold:

- The throttle position menu will appear. Scroll to highlight the throttle position that you will use to enable the mix. Press the jog dial to confirm your selection.
 - Scroll to select "ON" and press the jog dial to confirm your selection.

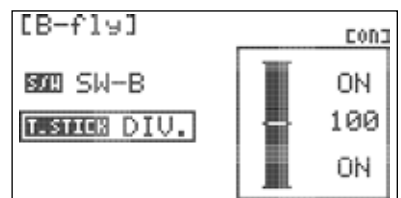

Butterfly Mixing (GLID Only) cont.

- Scroll to select the middle value field and press the jog dial to activate the menu.

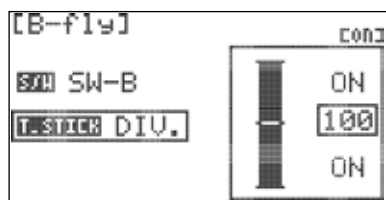

- Rotate the jog dial to position the top of the bar graph at the throttle position where the mix will be enabled. As you move the throttle stick, the field in the top right corner of the screen will indicate when the mix is active.

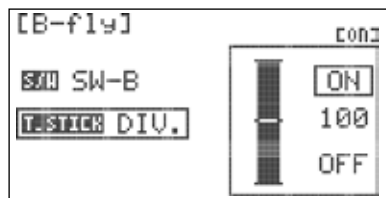

20. Press the back button four times to return to the model function menu.

To disable butterfly:

1. Scroll to highlight the "MIX" field in the butterfly menu and press the jog dial to activate the menu.
2. Select "INH" (inhibit) and press the jog dial to confirm your selection.
3. Press the back button to return to the model function menu.

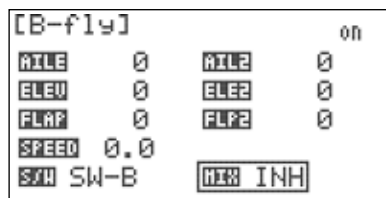
**Gyro**

It is often desirable to use a gyro to help stabilize one or more flight axis on fixed-wing models. The Flash 7 provides up to three gyro sensitivity settings per model memory. The gyro setting can also be specified for each defined flight condition.



The GYRO function must be assigned to a channel before this option will appear in the Model function menu. See Section 3 for instructions regarding the Channel menu.

1. From the model menu, rotate the jog dial to highlight "GYRO" and press the jog dial once to enter the activation menu.



2. Press the jog dial again to activate the menu.

3. Rotate the jog dial to select "ACT" (activate), then press the jog dial to confirm your selection and activate the gyro menu.

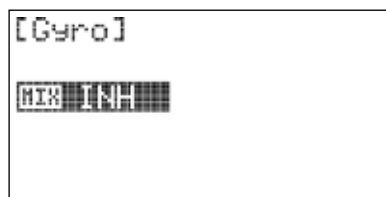

4. Scroll to the "RATE" field and press the jog button to activate the menu.

5. Scroll to dial in the desired amount of gyro gain (consult the gyro manufacturer's instructions for guidance).

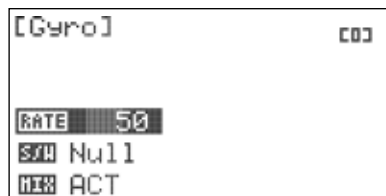

Gyro cont.

6. Scroll to highlight "S/W" and press the jog dial to activate the switch menu.
7. Scroll to select a switch to control the gyro. Press the jog dial to confirm your selection.
 - a. If you choose the "NULL" option, the set gyro rate will remain active at all times for this model.
 - b. If you choose a switch:
 - The current switch position will be displayed in the top right field of the display as "0", "1", or "2".
 - Repeat steps 4 and 5 to define gyro rate for every switch position.
 - c. If you choose "Cond" (Flight Condition):
 - The upper right field of the menu displays which flight condition is currently active and will be programmed
 - Scroll to the flight condition field and press the jog dial to activate the menu.
 - Choose the desired flight condition and press the jog dial to confirm your selection.

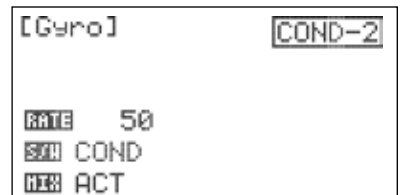
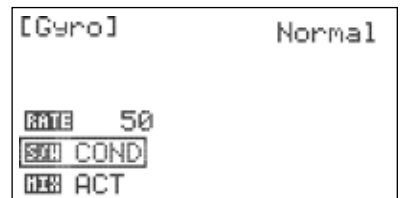
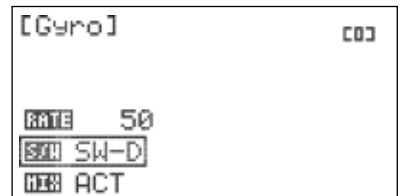
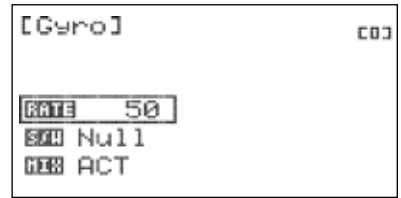

Tip

You may also select a flight condition in this menu by activating the desired flight condition.

- Repeat steps 4 and 5 to define the gyro rate for every flight condition.
8. Press the back button to return to the model function menu.

To disable the gyro:

1. Scroll to highlight the "MIX" field in the gyro menu and press the jog dial to activate the menu.
2. Select "INH" (inhibit) and press the jog dial to confirm your selection.
3. Press the back button to return to the model function menu.

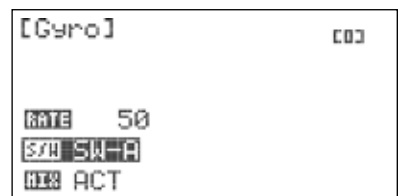

Throttle Cut (Acro Only)

Throttle Cut is a vital safety feature when flying glow or gas-powered models. This feature will command the throttle servo to a preprogrammed position with a switch movement. You may choose to set the servo to bring the engine to low-idle, or even shut it down.

Throttle Cut (Acro Only) cont.**To configure throttle cut:**

1. From the model menu, rotate the jog dial to highlight "THRO CUT" and press the jog dial once to enter the activation menu.

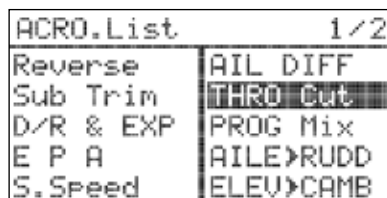

2. Press the jog dial again to activate the menu.

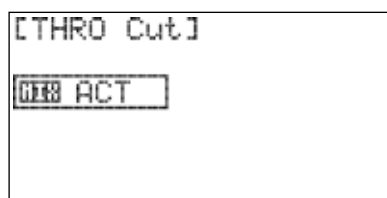

3. Rotate the jog dial to select ACT (activate), then press the jog dial to confirm your selection and activate the throttle cut menu.

4. Scroll to the "POS" (position) field and press the jog button to activate the menu.

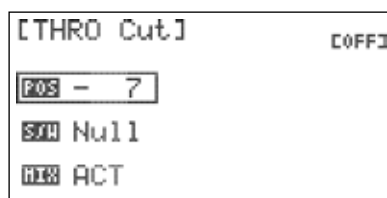

5. Rotate the jog dial to input the desired position of the throttle servo when throttle cut is activated. Models will typically require negative values to set a "kill engine" position. Ensure that the selected position does not cause the throttle servo to bind or place stress on the carburetor's control arm.

6. Scroll to highlight "S/W" and press the jog dial to activate the switch menu.

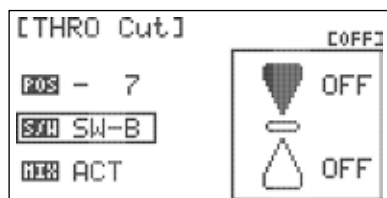

7. Scroll to select a switch to activate throttle cut. Press the jog dial to confirm your selection.

a. If you choose the "NULL" option, throttle cut will remain inactive at all times for this model.

b. If you choose a switch:

- The switch position menu will appear. Scroll to highlight the switch position that you will use to enable throttle cut. Press the jog dial to confirm your selection.

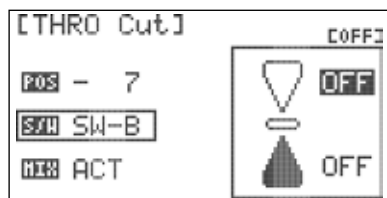

- Scroll to select "ON" and press the jog dial to confirm your selection. If you toggle the selected switch, the field in the top right corner of the screen will indicate when the mix is active.

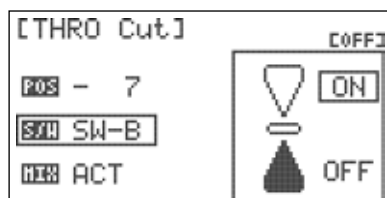

The momentary "deadman" switch (Switch-F) is a convenient and commonly-used throttle cut switch. Throttle cut should be off when the switch is in its neutral position.

Throttle Cut (Acro Only) cont.

8. Press the back button to return to the model function menu.

To disable throttle cut:

1. Scroll to highlight the "MIX" field in the throttle cut menu and press the jog dial to activate the menu.
2. Select "INH" (inhibit) and press the jog dial to confirm your selection.
3. Press the Back button to return to the model function menu.

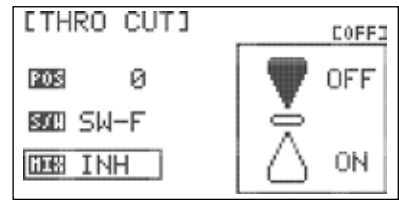

Throttle Curve

The Throttle Curve function allows you to modify the normally-linear servo rate movement for throttle by defining five different points along the throttle response curve.

To configure a throttle curve:

1. From the model menu, rotate the jog dial to highlight "T.Curve" and press the jog dial once to enter the activation menu.
2. Press the jog dial again to activate the menu.
3. Rotate the jog dial to select ACT (activate), then press the jog dial to confirm your selection and activate the throttle curve menu.
4. Scroll to the "1" field and press the jog button to activate the menu.
5. Rotate the jog dial to input the desired throttle position at this point on the curve (Throttle stick full down).
6. Repeat steps 4 and 5 for the remaining four steps on the throttle curve. As values are changed, the on-screen graph displays real-time updates to the throttle curve.
7. Scroll to the "EXP" (exponential) field and press the jog button to activate the menu.
8. Rotate the jog dial to select "OFF" or "ON". When "ON" is selected, the points in the curve are connected with exponential curves. Otherwise, the points are joined linearly. Press the jog dial to confirm your selection.
9. Scroll to highlight "S/W" and press the jog dial to activate the switch menu.
10. Scroll to select a switch to activate the throttle curve. Press the jog dial to confirm your selection.
 - a. If you choose the "NULL" option, the set throttle curve will remain active at all times for this model.

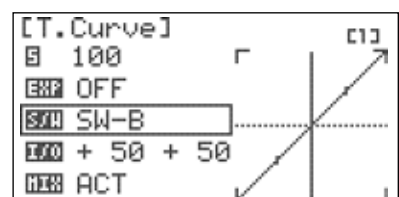
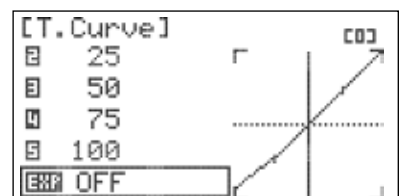
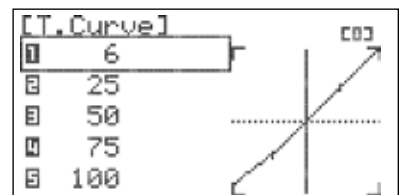
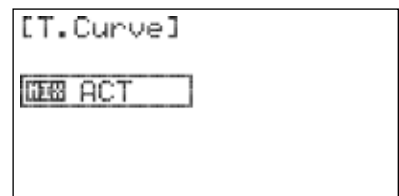
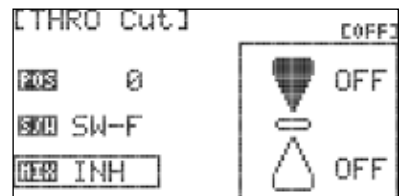

Throttle Curve cont.

b. If you choose a switch:

- The current switch position will be displayed in the top right field of the display as "0", "1", or "2".
- Repeat steps 4-8 to define throttle curve for every switch position.

11. Press the back button to return to the model function menu.

To disable the throttle curve:

1. Scroll to highlight the "MIX" field in the throttle curve menu and press the jog dial to activate the menu.
2. Select "INH" (inhibit) and press the jog dial to confirm your selection.
3. Press the back button to return to the model function menu.

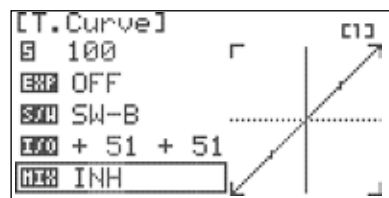

Helicopter Programming Menu

When the active model is configured as a helicopter model type, the model function menu contains programming options which are useful for helicopters. This section describes the features and programming steps for the helicopter model function menu.



The momentary “deadman” switch (Switch-F) is a convenient and commonly-used throttle cut switch. Throttle cut should be off when the switch is in its neutral position.

From the model function menu, you can program the following helicopter-specific options:

FLT.COND: Configure specific control settings for different phases of flight.

THRO CUT: Configure a kill switch for glow/gas motors.

T.HOLD: Set a switch-controlled throttle position.

GYRO: Specify gyro on/off and sensitivity settings.

REVO MIX: Damp unintended yaw movement when not using a heading hold gyro.

SWASH>THRO: Mix throttle with swashplate movements.

T.Curve: Specify non-linear throttle response.

P.Curve: Configure optimum blade pitch for different throttle settings.

***Swash Ring:** Prevent excessive control throw on the swash servos.

FLT.COND: Configure specific control settings for different phases of flight.

Working with Heli Model Function Menu

1. Turn on transmitter. When prompted to transmit, select “NO”.
2. Verify that the active model is a helicopter.
3. To access the model function menu, press and hold the jog dial.
4. The menu options shown reflect the parameters defined for the active model in the model type menu (Model Type and Swash). HELI-specific items are integrated in the menu with the options that are common to all model types.

HELI.List 1/2	
Reverse	Gyro
Sub Trim	THRO Cut
D/R & EXP	T.Hold
E P A	PROG Mix
S.Speed	REVO Mix

HELI.List 2/2	
Swash>THRO	Timer
Swash Mix	Monitor
T.Curve	Swash Ring
P.Curve	THRO Lock
F.COND	

Flight Conditions

The Flash 7 allows you to program up to four flight conditions. This powerful feature lets you define customized trim values and mix settings for different phases of flight.

The flight conditions for helicopter models are:

1. Normal
2. Idle-1
3. Idle-2
4. Hold

Flight Conditions cont.

The following features support flight condition programming in HELI mode:

Gyro
 Revolution Mix
 Swash > Throttle Mix
 Throttle Curve
 Pitch Curve

1. From the model menu, rotate the jog dial to highlight "F.COND" and press the jog dial once to enter the flight conditions menu.



2. Scroll to the flight condition to be configured and press the jog dial to confirm your selection.

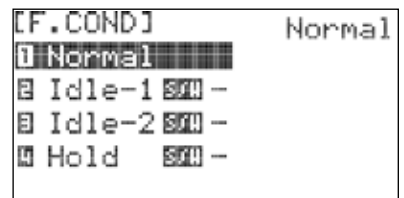

3. Press the jog dial again to activate the switch selection menu (not applicable in "Normal" flight condition).

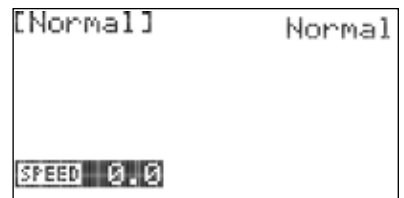

4. Scroll to select the switch that you will use to activate this flight condition and press the jog dial to confirm your selection.

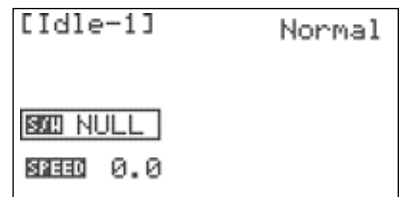

a. If "NULL" is selected, the flight condition will be inactive.

b. If you selected a switch, the switch position menu will appear.

- Scroll to highlight the switch position that you will use to enable the flight condition. Press the jog dial to confirm your selection.

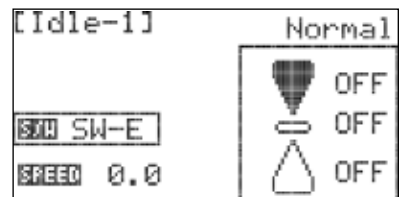

- Scroll to select "ON" and press the jog dial to confirm your selection. If you toggle the selected switch, the field in the top right corner of the screen will indicate which flight condition is active.

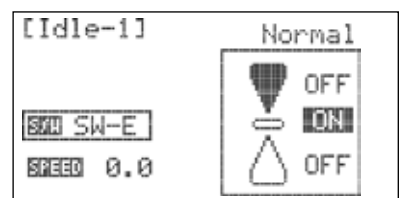

- Press the back button twice to return to the flight conditions menu.

Flight Conditions cont.



Note

If more than one flight condition is concurrently enabled, the condition with the highest number (per the table shown above) will be active. The field just below the model icon on the Home screen indicates the active flight condition.

5. Scroll to highlight the "SPEED" field and press the jog dial to activate the menu.

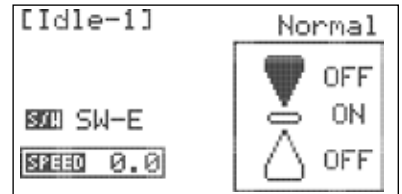

6. Scroll to define the amount of time (0.0 to 10.0 seconds) to transition the settings when this flight condition is enabled. Press the jog dial to confirm your selection. This feature can be utilized to prevent sudden control surface movements when switching between flight conditions.

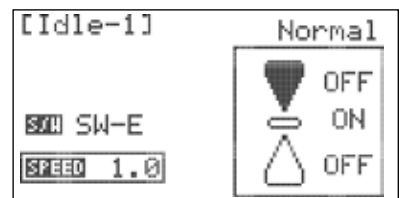

7. Press the back button to return to the flight conditions menu and repeat steps 2-6 to define further flight conditions.

8. Press the back button twice to return to the model function menu.

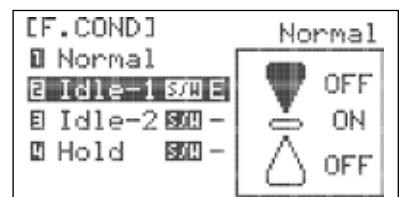

Throttle Cut

Throttle Cut is a vital safety feature when flying glow or gas-powered models. This feature will command the throttle servo to a preprogrammed position with a switch movement. You may choose to set the servo to bring the engine to low-idle, or even shut it down.

To configure throttle cut:

1. From the model menu, rotate the jog dial to highlight "THRO CUT" and press the jog dial once to enter the activation menu.

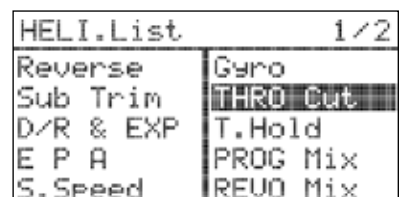

2. Press the jog dial again to activate the menu.
3. Rotate the jog dial to select ACT (activate), then press the jog dial to confirm your selection and activate the throttle cut menu.

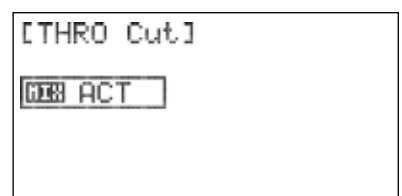

Throttle Cut cont.

4. Scroll to the "POS" (position) field and press the jog button to activate the menu.
5. Rotate the jog dial to input the desired position of the throttle servo when throttle cut is activated. Models will typically require negative values to set a "kill engine" position. Ensure that the selected position does not cause the throttle servo to bind or place stress on the carburetor's control arm.

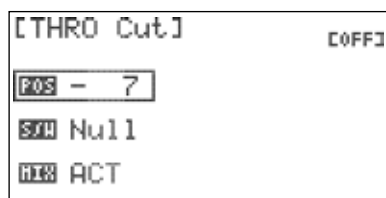

6. Scroll to highlight "S/W" and press the jog dial to activate the switch menu.

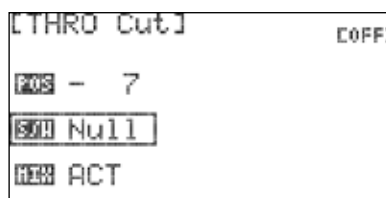

7. Scroll to select a switch to activate the camber mix. Press the jog dial to confirm your selection.

a. If you choose the "NULL" option, throttle cut will remain inactive at all times for this model.

b. If you choose a switch:

- The switch position menu will appear. Scroll to highlight the switch position that you will use to enable throttle cut. Press the jog dial to confirm your selection.

- Scroll to select "ON" and press the jog dial to confirm your selection. If you toggle the selected switch, the field in the top right corner of the screen will indicate when the mix is active.

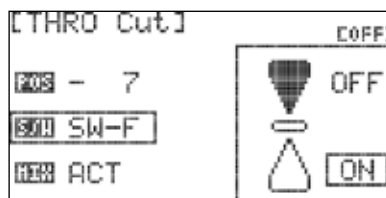

The momentary "deadman" switch (Switch-F) is a convenient and commonly-used throttle cut switch. Throttle cut should be off when the switch is in its neutral position.

8. Press the Back button to return to the Model Function menu.

To disable Throttle Cut:

1. Scroll to highlight the "MIX" field in the Throttle Cut menu and press the jog dial to activate the menu.
2. Select "INH" (inhibit) and press the jog dial to confirm your selection.
3. Press the Back button to return to the Model Function menu.

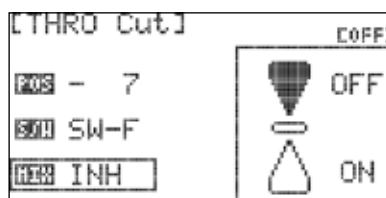

Throttle Hold

Throttle hold is used to set the throttle at a programmed position while still allowing the throttle stick to control blade pitch. This function is often used to facilitate auto-rotation maneuvers.



The throttle hold feature will not work unless a hold position has been assigned a switch using the flight condition/idle-up function as was done on page 57.

Throttle Hold cont.

1. From the Model menu, rotate the jog dial to highlight T.HOLD and press the jog dial once to enter the activation menu.



2. Press the jog dial again to activate the menu.

3. Rotate the jog dial to select ACT (activate), then press the jog dial to confirm your selection and activate the T.Hold menu.

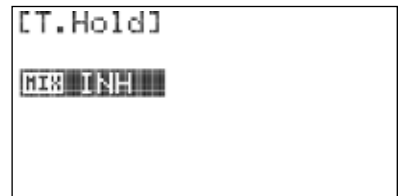

4. Scroll to the "RATE" field and press the jog button to activate the menu.

5. Use the jog dial to place a rate value for the hold position you want the throttle to be at when the hold switch is activated.

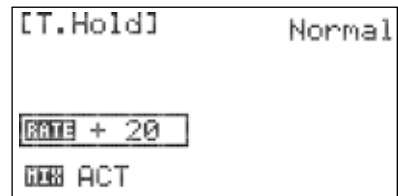

To disable the T.HOLD function:

1. Scroll to highlight the "MIX" field in the T.HOLD menu and press the jog dial to activate the menu.

2. Select "INH" (inhibit) and press the jog dial to confirm your selection.

3. Press the Back button to return to the Model Function menu.

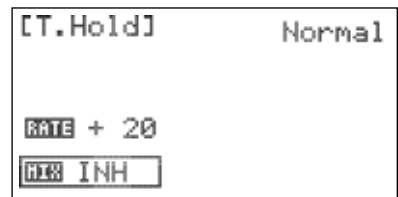

Gyro

It is often desirable to use a gyro to help stabilize the tail rotor on helicopters. The Flash 7 provides up to three gyro sensitivity settings per model memory. The gyro setting can also be specified for each defined flight condition.



The GYRO function must be assigned to a channel before this option will appear in the Model function menu. See Section 3 for instructions regarding the Channel menu.

1. From the Model menu, rotate the jog dial to highlight "GYRO" and press the jog dial once to enter the activation menu.

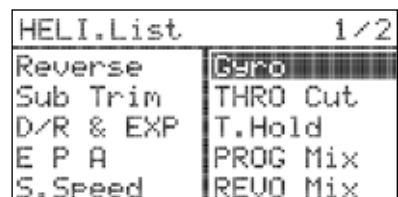

2. Press the jog dial again to activate the menu.

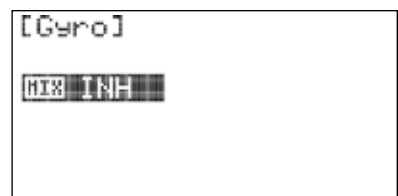

Gyro cont.

3. Rotate the jog dial to select ACT (activate), then press the jog dial to confirm your selection and activate the GYRO menu.

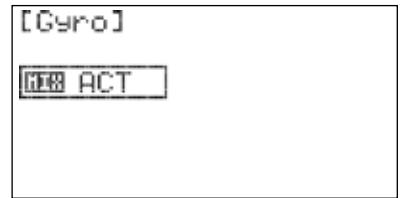

4. Scroll to the "MODE" field and press the jog button to activate the menu.

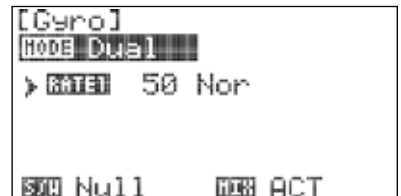

5. Scroll to select "Single" or "Dual" to denote whether your gyro is a single-rate or dual-rate unit. Consult the gyro manufacturer's instructions if you are not sure. Press the jog dial to confirm your selection.

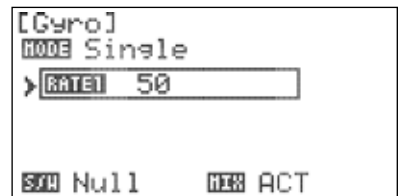

a. If you choose "Single":

- Scroll to the "RATE1" field and press the jog button to activate the menu.
- Scroll to dial in the desired amount of gyro gain (consult the gyro manufacturer's instructions for guidance).

b. If you choose "Dual":

- Scroll to the "RATE1" field and press the jog button to activate the menu.
- Scroll to highlight the value field and press the jog dial to activate the selections.
- Scroll to dial in the desired amount of gyro gain (consult the gyro manufacturer's instructions for guidance).

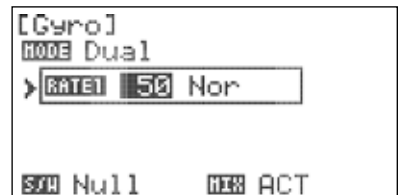

- Scroll to highlight the function field ("Nor" or "T.lock") and press the jog dial to activate the menu.
- Scroll to select "Nor" (normal) or "T.lock" (throttle lock). Throttle lock is used for bench testing the gyro rate sensitivity.

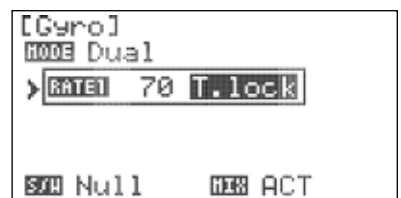
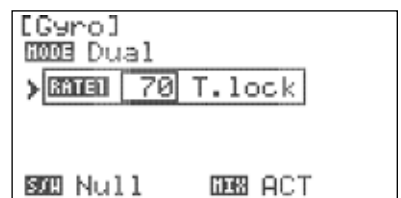

6. Scroll to highlight "S/W" and press the jog dial to activate the switch menu.

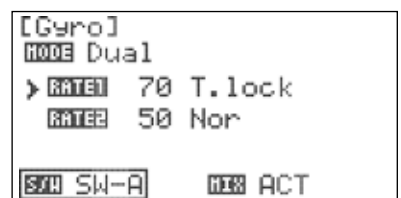

7. Scroll to select a switch to activate the gyro rate mix. Press the jog dial to confirm your selection.

a. If you choose the "NULL" option, the set gyro rate will remain active at all times for this model.

Gyro cont.

b. If you choose a switch:

- The current switch position will be displayed next to the rate which is currently activated by the switch's position.
- Repeat step 5a or 5b as applicable to define gyro rate for every switch position.

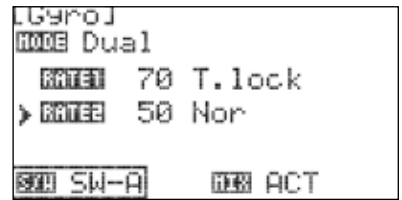

c. If you choose "Cond" (Flight Condition):

- The upper right field of the menu displays which flight condition is currently active and will be programmed.
- Scroll to the Flight Condition field and press the jog dial to activate the menu.
- Choose the desired flight condition and press the jog dial to confirm your selection.

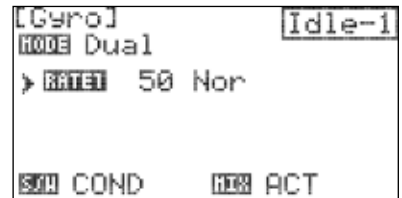

Tip

You may also select a flight condition in this menu by activating the desired flight condition.

- Repeat step 5a or 5b as applicable to define the gyro rate for every flight condition.

To disable the Gyro:

10. Scroll to highlight the "MIX" field in the Gyro menu and press the jog dial to activate the menu.
11. Select "INH" (inhibit) and press the jog dial to confirm your selection.
12. Press the Back button to return to the Model Function menu.

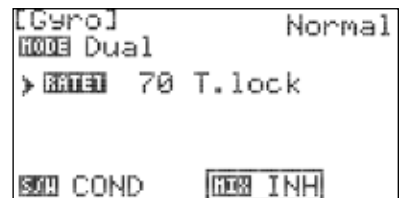

Revolution Mixing

The revolution mix is used to prevent yaw effects caused by changes in head speed or blade pitch on the main rotor. It is not needed on helicopters equipped with a heading hold gyro.

To configure a revolution mix:

1. From the Model menu, rotate the jog dial to highlight "REVO Mix" and press the jog dial once to enter the activation menu.

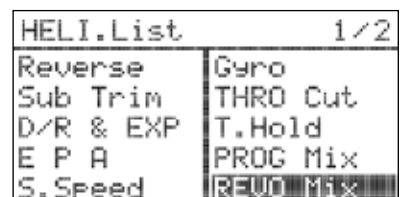

2. Press the jog dial again to activate the menu.
3. Rotate the jog dial to select ACT (activate), then press the jog dial to confirm your selection and activate the GYRO menu.

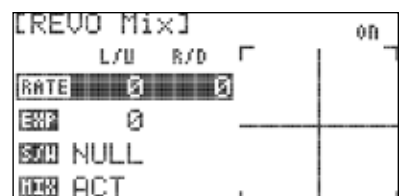

Revolution Mixing cont.

4. Scroll to the "RATE" field and press the jog button to activate the menu.

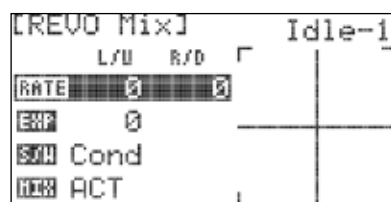

5. Scroll to highlight the "L/U" (left/up) field and press the jog dial to activate the menu.

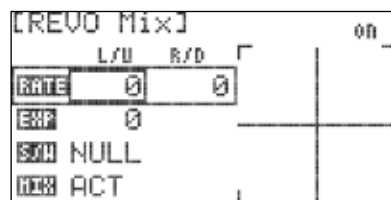

6. Rotate the jog dial to set the position for the tail rotor pitch servo when the throttle stick is full down. Press the jog dial to confirm your input.

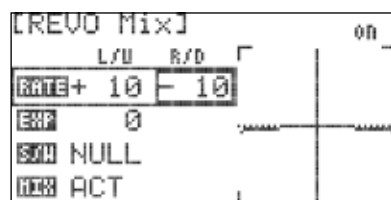

7. Scroll to highlight the "R/D" (right/down) field and press the jog dial to activate the menu.

8. Rotate the jog dial to set the position for the tail rotor pitch servo when the throttle stick is full up. Press the jog dial to confirm your input.

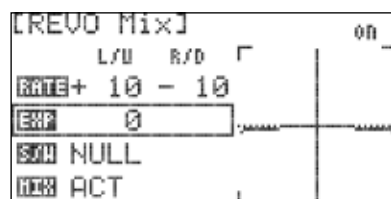

9. Scroll to highlight the "EXP" field and press the jog dial to activate the menu.

10. Rotate the jog dial to increase (clockwise) or decrease (counter-clockwise) the desired exponential value for this mix. This value does not affect exponential throw of the servo with rudder stick commands. Press the jog dial to confirm your input.

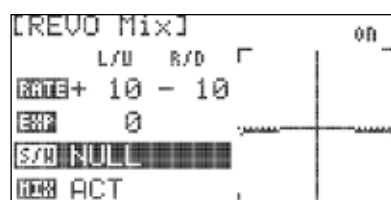

11. Scroll to highlight "S/W" and press the jog dial to activate the switch menu.

12. Scroll to select a switch to activate the camber mix. Press the jog dial to confirm your selection.

a. If you choose the "NULL" option, revolution mix will remain active at all times for this model.

b. If you choose a switch:

- The switch position menu will appear. Scroll to highlight the switch position that you will use to enable revolution mix. Press the jog dial to confirm your selection.

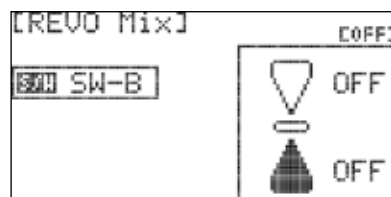

- Scroll to select "ON" and press the jog dial to confirm your selection. If you toggle the selected switch, the field in the top right corner of the screen will indicate when the mix is active.

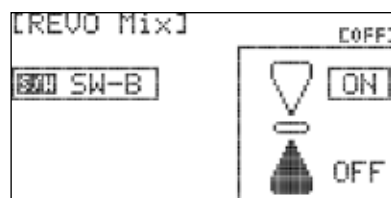

Revolution Mixing cont.

c. If you choose "Cond" (Flight Condition):

- The upper right field of the menu displays which flight condition is currently active and will be programmed.

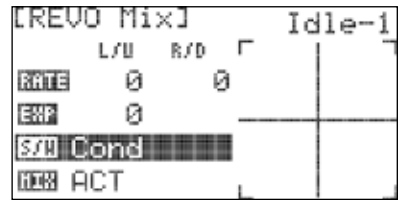

- Scroll to the Flight Condition field and press the jog dial to activate the menu.
- Choose the desired flight condition and press the jog dial to confirm your selection.

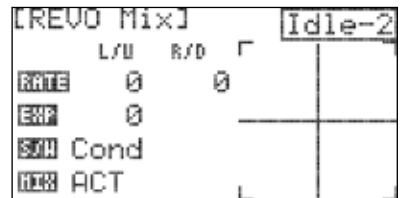

Tip

You may also select a flight condition in this menu by activating the desired flight condition.

13. Repeat step 12b as applicable to define the REVO Mix for every flight condition.

14. Press the Back button to return to the Model Function menu.

To disable the revolution mix:

1. Scroll to highlight the "MIX" field in the Revolution Mix menu and press the jog dial to activate the menu.
2. Select "INH" (inhibit) and press the jog dial to confirm your selection.
3. Press the Back button to return to the Model Function menu.

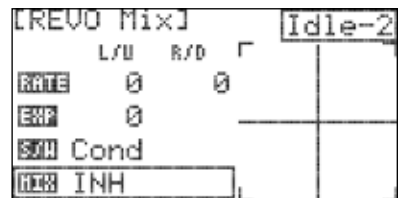

Swash to Throttle Mixing

A swash to throttle mix is typically used to increase main rotor RPM when a swash control command is input to the helicopter. The increased RPM compensates for the loss of lift due to tilting the rotor.

1. From the Model menu, rotate the jog dial to highlight "SWASH>THRO" and press the jog dial once to enter the activation menu.



2. Press the jog dial again to activate the menu.
3. Rotate the jog dial to select ACT (activate), then press the jog dial to confirm your selection and activate the swash-throttle menu.

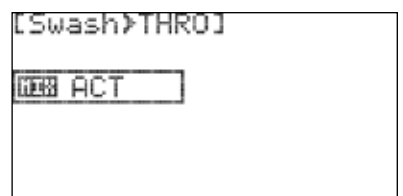

Swash to Throttle Mixing cont.

4. Scroll to the function field ("AILE" or "ELEV"). If "AILE" is not the current function, press the jog dial to activate the menu. Otherwise, skip to step 6.

5. Scroll to select "AILE" and press the jog dial to confirm your selection.

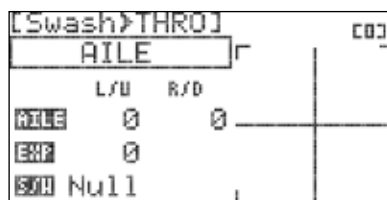

6. Scroll to the top row of the value table ("AILE") and press the jog dial to activate the menu.

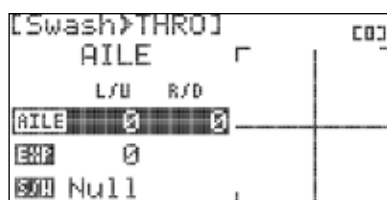

7. Scroll to highlight the "L/U" (left/up) field and press the jog dial to activate the menu.

8. Rotate the jog dial to input the desired throttle compensation when a left roll command is given. Press the jog dial to confirm your input.

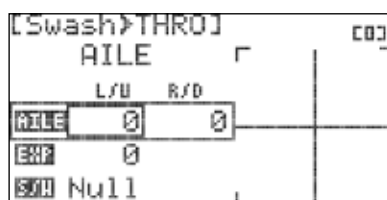

9. Scroll to highlight the "R/D" (right/down) field and press the jog dial to activate the menu.

10. Rotate the jog dial to input the desired throttle compensation when a right roll command is given.

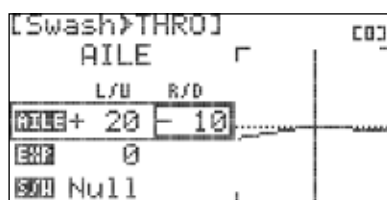

11. Scroll to highlight the "EXP" field and press the jog dial to activate the selection.

12. Rotate the jog dial to input the desired exponential travel of the throttle servos when reacting to this mix. The setting does not affect exponential travel of the servo when throttle stick inputs are given.

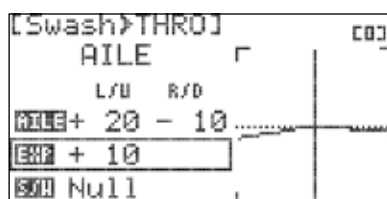

13. Scroll to the function field and press the jog dial to activate the menu. Otherwise, skip to step 17.

14. Scroll to select "ELEV" and press the jog dial to confirm your selection.

15. Repeat steps 6-12 to input throttle compensation values for elevator inputs.



16. Scroll to highlight "S/W" and press the jog dial to activate the switch menu.

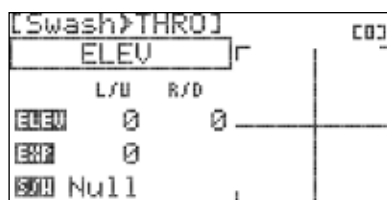

Swash to Throttle Mixing cont.

17. Scroll to select a switch to activate the swash-throttle mix. Press the jog dial to confirm your selection.

a. If you choose the "NULL" option, the set mix values will remain active at all times for this model.

b. If you choose a switch:

- The current switch position will be displayed in the top right field of the display as "0", "1", or "2".
- Repeat steps 4-15 as applicable to define a swash-throttle mix for every switch position.



c. If you choose "Cond" (Flight Condition):

- The upper right field of the menu displays which flight condition is currently active and will be programmed.

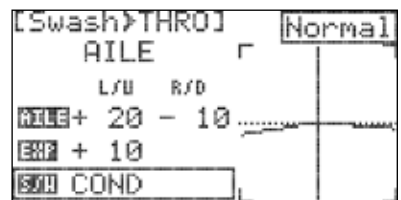

- Scroll to the Flight Condition field and press the jog dial to activate the menu.
- Choose the desired flight condition and press the jog dial to confirm your selection.

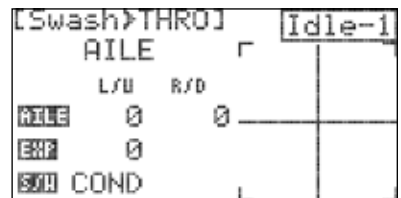

Tip

You may also select a flight condition in this menu by activating the desired flight condition.

- Repeat steps 4-15 as applicable to define a swash-throttle mix for every flight condition.

To disable the revolution mix:

1. Scroll to highlight the "MIX" field in the Revolution Mix menu and press the jog dial to activate the menu.
2. Select "INH" (inhibit) and press the jog dial to confirm your selection.
3. Press the Back button to return to the Model Function menu.

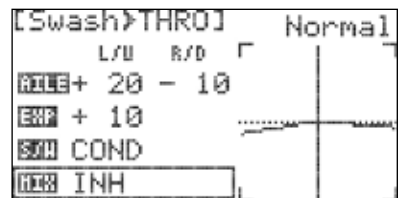

Swash Mixing

Swash Plate Adjustment Menu.

Use the swash mix feature to apply a fine adjustment to the swash plate travel. For the very best accuracy, we recommend the use of a swash plate leveling set-up tool.



Tip

As this is a set-up feature, swash mix is one of the few functions that is NOT influenced by flight conditions, idle-up or hold conditions.

Our example will show a 120CCPM head format.

1. From the model menu, scroll to highlight “Swash Mix” and press the jog dial once to enter the sub trim menu.



2. Scroll to the functions (AILE,ELEV,Pitch) to be adjusted and press the jog dial to activate the menu.

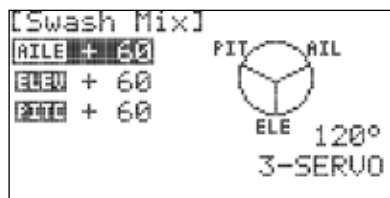

3. Rotate the jog dial clockwise or counter-clockwise to alter the Individual collective servos.

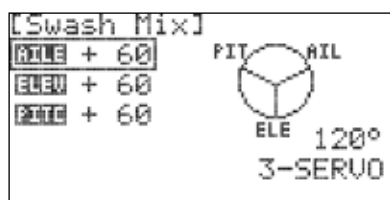
**Tip**

With all the servos hooked up, and the transmitter and receiver turned on, move the throttle/collective stick up and down. The swash should move up and down with no rotations. Move the aileron stick left and right. The swash should tilt left and right without pitching or rising. Move the elevator stick. The swash should tilt fore and aft with no rotations. If there are rotations when collective is moved, or the swash moves up and down with aileron or elevator, you need to adjust the settings in the swash menu. If the servos do not all respond in the same direction for collective or opposite directions for aileron and elevator, you will need to reverse one or more of them in the reversing menu (Reverse). It may take a little trial and error using different combinations of normal and reverse rotation to get the servos to respond properly. Don't worry about the direction they respond, just that they all move the same for collective and tilt for aileron and elevator.

Throttle Curve

The Throttle Curve function allows you to modify the normally-linear servo rate movement for throttle by defining five different points along the throttle response curve. It is necessary to manipulate the throttle curve in conjunction with the pitch curve to achieve maximum performance from your helicopter.

To configure a throttle curve:

1. From the Model menu, rotate the jog dial to highlight “T.Curve” and press the jog dial once to enter the activation menu.



Throttle Curve cont.

2. Press the jog dial again to activate the menu.

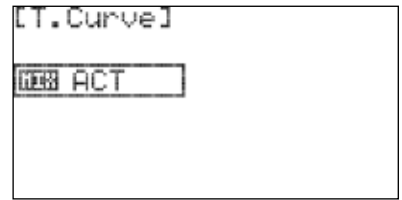

3. Rotate the jog dial to select ACT (activate), then press the jog dial to confirm your selection and activate the throttle curve menu.

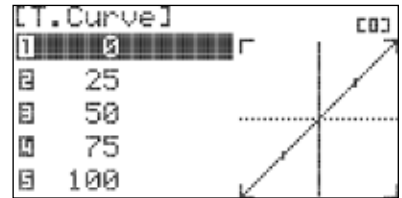

4. Scroll to the "1" field and press the jog button to activate the menu.

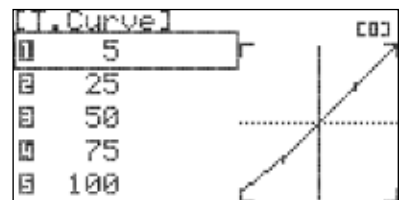

5. Rotate the jog dial to input the desired throttle position at this point on the curve (Throttle stick full down).

6. Repeat steps 4 and 5 for the remaining four steps on the throttle curve. As values are changed, the on-screen graph displays real-time updates to the throttle curve.

7. Scroll to the "EXP" (exponential) field and press the jog button to activate the menu.

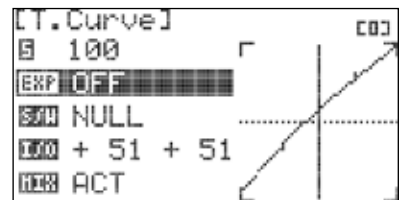

8. Rotate the jog dial to select "OFF" or "ON". When "ON" is selected, the points in the curve are connected with exponential curves. Otherwise, the points are joined linearly. Press the jog dial to confirm your selection.

9. Scroll to highlight "S/W" and press the jog dial to activate the switch menu.

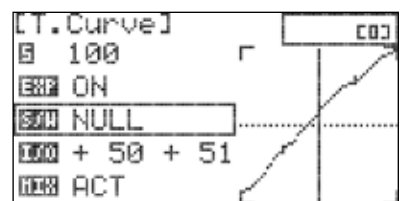

10. Scroll to select a switch to activate the camber mix. Press the jog dial to confirm your selection.

a. If you choose the "NULL" option, the set throttle curve will remain active at all times for this model.

b. If you choose a switch:

- The current switch position will be displayed in the top right field of the display as "0", "1", or "2".
- Repeat steps 4-8 to define throttle curve for every switch position.

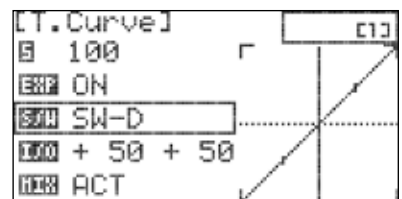

c. If you choose "Cond" (Flight Condition):

- The upper right field of the menu displays which flight condition is currently active and will be programmed.

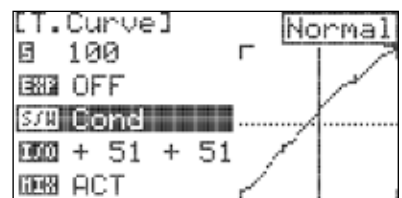

Throttle Curve cont.

- Scroll to the flight condition field and press the jog dial to activate the menu.
- Choose the desired flight condition and press the jog dial to confirm your selection.

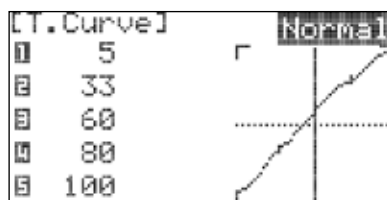

Tip

You may also select a flight condition in this menu by activating the desired flight condition.

11. Press the back button to return to the model function menu.

To disable the throttle curve:

1. Scroll to highlight the "MIX" field in the throttle curve menu and press the jog dial to activate the menu.
2. Select "INH" (inhibit) and press the jog dial to confirm your selection.
3. Press the Back button to return to the model function menu.

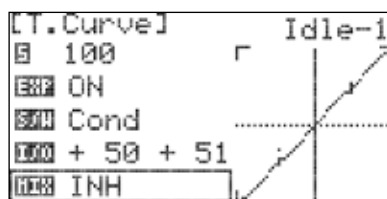
**Pitch Curve**

The Pitch Curve function allows you to modify the normally-linear servo rate movement for collective pitch by defining five different points along the pitch response curve. It is necessary to manipulate the pitch curve in conjunction with the throttle curve to achieve maximum performance from your helicopter.

To configure a pitch curve:

1. From the model menu, rotate the jog dial to highlight "P.Curve" and press the jog dial once to enter the activation menu.



2. Press the jog dial again to activate the menu.
3. Rotate the jog dial to select ACT (activate), then press the jog dial to confirm your selection and activate the pitch curve menu.

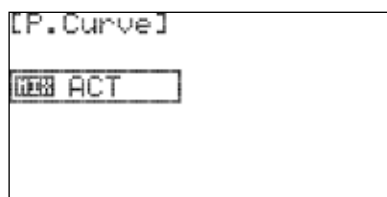

4. Scroll to the "1" field and press the jog button to activate the menu.

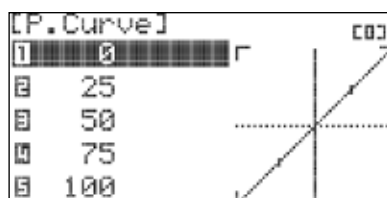

Pitch Curve cont.

5. Rotate the jog dial to input the desired pitch position at this point on the curve (Throttle stick full down).

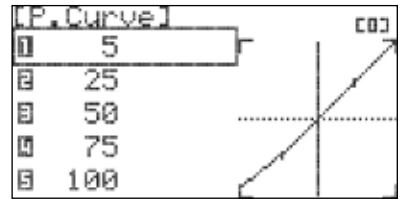

6. Repeat steps 4 and 5 for the remaining four steps on the pitch curve. As values are changed, the on-screen graph displays real-time updates to the pitch curve.

7. Scroll to the "EXP" (exponential) field and press the jog dial button to activate the menu.

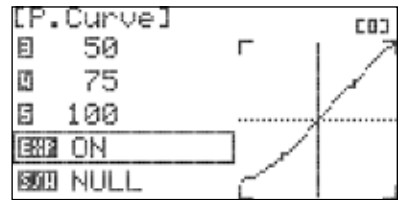

8. Rotate the jog dial to select "OFF" or "ON". When "ON" is selected, the points in the curve are connected with exponential curves. Otherwise, the points are joined linearly. Press the jog dial to confirm your selection.

9. Scroll to highlight "S/W" and press the jog dial to activate the switch menu.

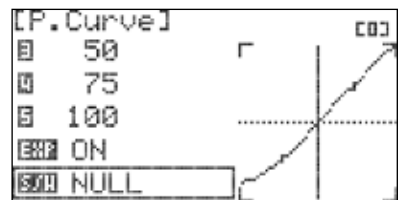

10. Scroll to select a switch to activate the camber mix. Press the jog dial to confirm your selection.

a. If you choose the "NULL" option, the set pitch curve will remain active at all times for this model.

b. If you choose a switch:

- The current switch position will be displayed in the top right field of the display as "0", "1", or "2".
- Repeat steps 4-8 to define pitch curve for every switch position.

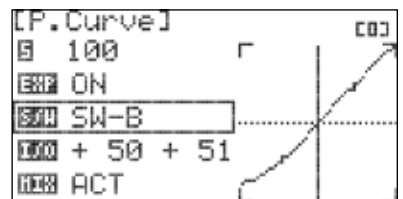

c. If you choose "Cond" (Flight Condition):

- The upper right field of the menu displays which flight condition is currently active and will be programmed.

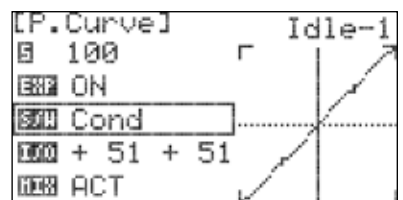

- Scroll to the flight condition field and press the jog dial to activate the menu.
- Choose the desired flight condition and press the jog dial to confirm your selection.
- Repeat steps 4-8 as applicable to define a pitch curve for every flight condition.

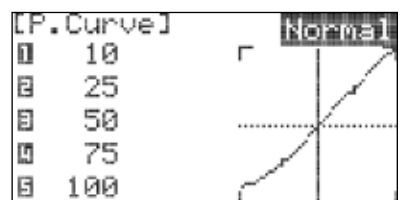

Pitch Curve cont.

Tip

You may also select a flight condition in this menu by activating the desired flight condition.

11. Press the back button to return to the model function menu.

To disable the pitch curve:

1. Scroll to highlight the "MIX" field in the pitch curve menu and press the jog dial to activate the menu.
2. Select "INH" (inhibit) and press the jog dial to confirm your selection.
3. Press the Back button to return to the model function menu.

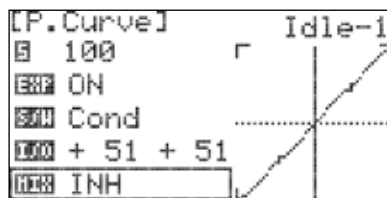
**Swash Ring**

The Swash Ring Mix limits the travel of the servos attached to the helicopter swash plate. This can be used to help prevent binding of the control system when using large control movements for aerobatics. There are no adjustments to the swash ring mix.

1. From the model menu, rotate the jog dial to highlight "Swash Ring" and press the jog dial once to enter the activation menu.



2. Press the jog dial again to activate the menu.

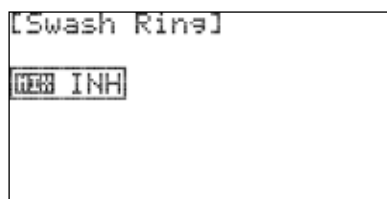

3. Rotate the jog dial to select ACT (activate), then press the jog dial to confirm your selection and activate the Swash Ring mix.
4. Press the back button to return to the model function menu.

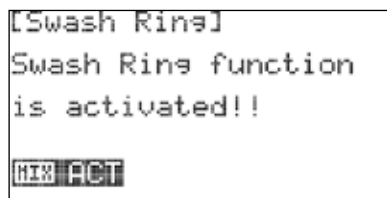

Using the Telemetry

When paired with an Optima 7 or Optima 9 receiver, the Flash 7 is fully compatible with Hitec's suite of telemetry sensors. The ability to receive important data from the model is critical to preventing crashes due to dead batteries, an empty fuel tank, or overheated components. Additionally, telemetry data is priceless when fine-tuning your model to reach the peak of its performance capability. With each tweak to your model, you can generate empirical data to understand the performance effects of the change.

All Optima receivers will report the receiver battery voltage without the need for an add-on sensor. All other types of data require a sensor as well as a sensor station. A single sensor station can accommodate numerous and varied sensors. The sensor station and sensors that you choose are dependent on the model's power system and/or the type of data that you wish to collect. Visit Hitec's website (www.hitecrd.com) for details on the sensor stations and sensors that are available.

In the Flash 7 Sensor menu, you will find the following telemetry parameters:

GPS – Global Positioning System device capable of determining precise location and speed data.

RPM – Provides RPM data for electric, glow or gas motors.

TEMP – Provides temperature data from multiple sensors.

Battery – Provides power system parameters for electric aircraft and receiver voltage data for all types of models.

Servo – Provides current draw data for servos.

Advanced – Provides airspeed and altitude rate-of-change data.

Working with the Sensor Menu

1. Verify that the model is linked to an Optima receiver.
2. Verify that the sensors and sensor station are connected per their respective manuals (only valid for Optima 7 and Optima 9).
3. Turn on the transmitter. When prompted to transmit, select "YES".
4. Turn on the receiver's power source.
5. To access the transmitter's SENSOR menu, simultaneously press the back button and jog dial.
6. Scroll to "SENSOR" and press the jog dial to activate the menu.

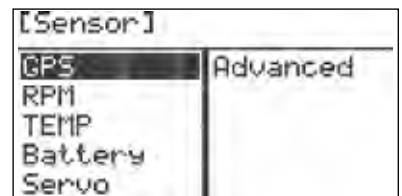

GPS

The GPS screen displays real-time latitude, longitude, altitude and speed data.

Required Sensor: HTS-GPS GPS Sensor.

GPS cont.

1. From the sensor menu, rotate the jog dial to highlight “GPS” and press the jog dial once to enter the GPS menu.
2. Scroll to the “UNIT” field and press the jog dial to confirm your selection.

```
[GPS]
LATITUDE
LONGITUDE
ALTITUDE  0  SPEED  0
UNIT Metric
ALT ABSOLUTE
```

3. Scroll to select “Metric” (meters, meters per second) or “Imperial” (feet, feet per second) units and press the jog dial to confirm your selection.

```
[GPS]
LATITUDE
LONGITUDE
ALTITUDE  0  SPEED  0
UNIT Imperial
ALT ABSOLUTE
```

4. Scroll to the “ALT” field and press the jog dial to confirm your selection.

```
[GPS]
LATITUDE
LONGITUDE
ALTITUDE  0  SPEED  0
UNIT Metric
ALT RELATIVE
```

5. Scroll to select “RELATIVE” or “ABSOLUTE”. Relative mode is the most commonly used option. . In this setting, altitude is displayed as the model’s height above the launch altitude. If absolute is selected, the altitude will be displayed as the model’s height above sea level.
6. Press the back button to return to the sensor menu.

RPM

The RPM screen displays rpm data for electric, glow, or gas motors in an airplane or helicopter. Data from two sensors can be displayed simultaneously.

Required Sensor: HTS-MRPM Magnetic RPM Sensor or HTS-ORPM Optical RPM Sensor.

1. From the sensor menu, rotate the jog dial to highlight “RPM” and press the jog dial once to enter the RPM menu.

```
[RPM]
RPM1  0 / UNIT Prop-M
RPM2  0 / UNIT Prop-M
```

2. Scroll to the top “UNIT” field and press the jog dial to confirm your selection.

```
[RPM]
RPM1  0 / UNIT Prop-M
RPM2  0 / UNIT Prop-M
```

RPM cont.

3. Scroll to select "Prop-M" using the magnetic RPM sensor. If using an optical sensor, select "Prop-2", "Prop-3" or "Prop-4". The numeral indicates the number of blades on your propeller. Press the jog dial to confirm your selection.

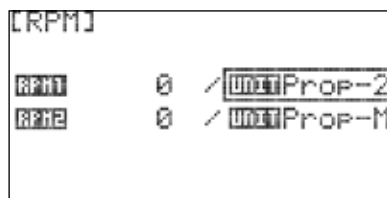

4. If you are using a second RPM sensor, repeat steps 2 and 3 on the lower "UNIT" field.
5. Press the back button to return to the sensor menu.

Temperature

The TEMP screen displays temperature readings from as many as four separate temperature sensors. An additional field (H.TEM) displays the highest temperature recorded during the flight.

Required Sensor: HTS-TEMP Temperature Sensor or HTS-eTEMP Engine Temperature Sensor.

1. From the sensor menu, rotate the jog dial to highlight "TEMP" and press the jog dial once to enter the temperature menu.

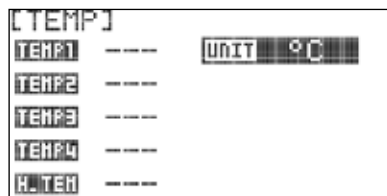

2. Press the jog dial again to activate the "UNIT" field.

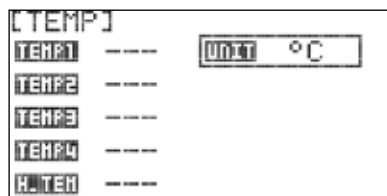

3. Scroll to select "°F" or "°C". Choose °F to receive temperature in degrees Fahrenheit, and °C for degrees Celsius. Press the jog dial to confirm your selection.

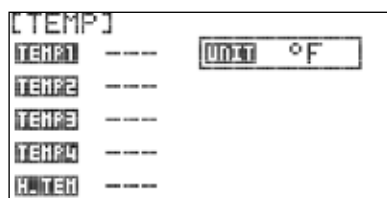

4. Press the back button to return to the sensor menu.

Battery

The Battery screen displays the voltage of the receiver battery (no sensor is required for this data). Additionally, this screen displays flight pack voltage, motor current, and motor wattage for electric-powered models.

Required Sensor: HTS-C50 50-Amp Current Sensor or HTS-C200 200-Amp Current Sensor.



Tip

Receiver battery voltage is also displayed on the lower right corner of the Flash 7 home screen.

Battery cont.

1. From the sensor menu, rotate the jog dial to highlight "BATTERY" and press the jog dial once to enter the battery menu.

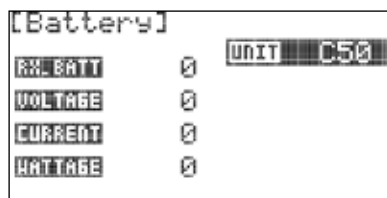

2. Press the jog dial again to activate the "UNIT" field.

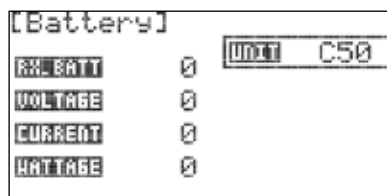

3. Scroll to select "C50" if using the 50-amp current sensor or "C200" if using the 200-amp current sensor. Press the jog dial to confirm your selection.

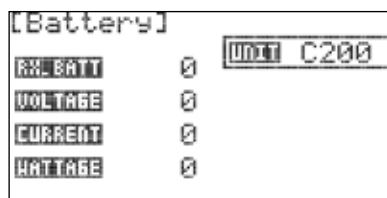

4. Press the back button to return to the sensor menu.

Servo Manager

The Servo screen displays the current draw for each servo attached to the outputs of the Servo Manager sensor.



Note

If multiple servos are attached to a single sensor output using a Y-harness, the display will show the total amperage for all servos connected to that output.

Required Sensor: HTS-SM Servo Manager Sensor (compatible only with the HTS-SS Advanced Sensor Station).

1. From the sensor menu, rotate the jog dial to highlight "Servo" and press the jog dial once to enter the Servo screen.
2. Press the back button to return to the sensor menu.

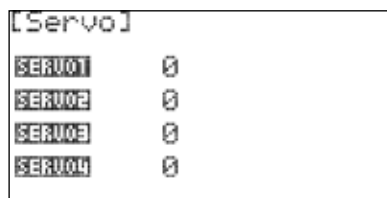

Advanced Telemetry Sensors

The Advanced screen displays airspeed data collected from Hitec's dedicated airspeed sensor (not GPS), as well as rate-of-climb data collected by a variometer.

Required Sensor: HTS-AS Air Speed Sensor and HTS-VM Variometer Sensor (both sensors are compatible only with the HTS-SS Advanced Sensor Station).

1. From the sensor menu, rotate the jog dial to highlight "Advanced" and press the jog dial once to enter the advanced menu.

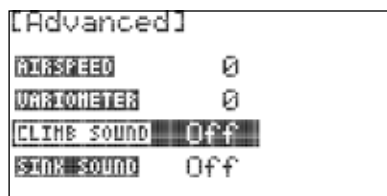

Advanced Telemetry Sensors cont.

2. Scroll to the “CLIMB SOUND” field and press the jog dial to confirm your selection.

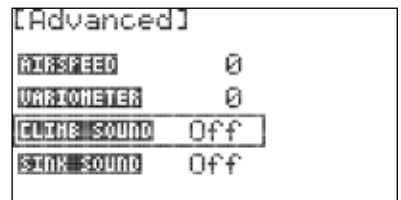

3. Scroll to select “ON” if you would like the transmitter to emit a tone when the model is gaining altitude. Otherwise, select “OFF”. Press the jog dial to confirm your selection.

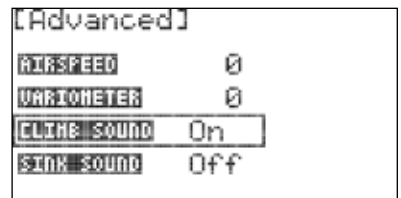

4. Scroll to the “SINK SOUND.” field and press the jog dial to confirm your selection.

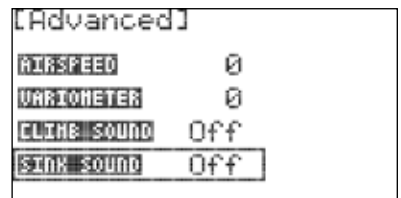

5. Scroll to select “ON” if you would like the transmitter to emit a tone when the model is losing altitude. Otherwise, select “OFF”. Press the jog dial to confirm your selection.

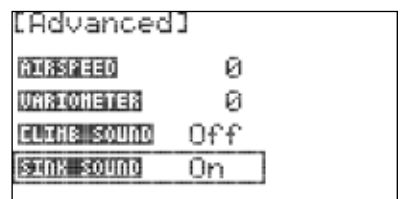

6. Press the back button to return to the sensor menu.

Viewing Telemetry Data

While the various sensor screens on the Flash 7 display can be used to view real-time telemetry data, it is often inconvenient or unsafe to use them while flying. In these cases, there are interface options which provide convenient and safe solutions.

The Flash 7 is compatible with the HPP-22 (wired) and HTS-NAVI (wireless) PC Interface modules. When using either module in conjunction with the HPP-22 software, the telemetry data can be viewed in a large dashboard-type format that is highly customizable. Additionally, these interface modules permit logging of telemetry data for post-flight playback and analysis.

You may also utilize the HTS-Voice Telemetry Voice Announcing System. This speaker system attaches to the transmitter handle and provides periodic voice announcements of selected telemetry data during your flight. You can configure the data that is reported as well as the frequency of the announcements. The module is also equipped with a headphone jack. Using ear bud-type speakers in this jack is a practical method to hear the voice announcements at noisy flying sites and/or to avoid disturbing nearby pilots.

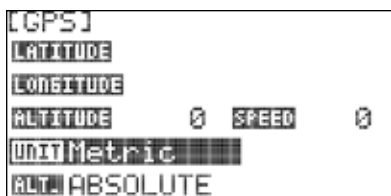

Stick Length Adjustment

Hands come in all sizes so, to accommodate everyone, we use a two piece stick “top” that can be adjusted to fit a wide variety of users.

Separate the top from the bottom piece and adjust the top piece to the length required. Screw the bottom up against the top piece to “jam” lock everything into position.

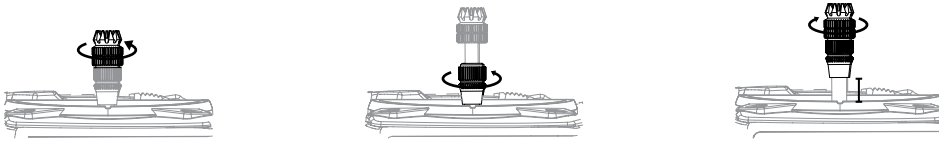

Stick Lever Tension Adjustment / Mode Change

Stick Lever Tension Adjustment

You may adjust the stick tension of your sticks to provide the “feel” that you like for flying. To adjust your springs, you’ll have to remove the rear case of the transmitter. Using a screwdriver, remove the four screws that hold the transmitter’s rear cover into position and put them in a safe place.

Gently ease off the transmitter’s rear cover. Now you’ll see the view shown. Using a small cross-point screwdriver, rotate the adjusting screw for each stick for the desired spring tension. The tension increases when the adjusting screw is turned clockwise, and decreases for counterclockwise motion.



Note

Please use 1.5mm hex key for gimbals’ tension adjustment and mode changes.

When you are satisfied with the spring tensions, you may close the transmitter.

Very carefully reinstall the rear cover.

When the cover is properly in place, tighten the four screws.

Change to ‘Mode 1’ Configuration

All Flash 7 systems sold in the US are in ‘Mode 2’ format. However, you may wish to use Flash 7 in ‘mode 1’ format. There is a menu choice for this option in the Initial Set-Up function menu described on Page 26.

After selecting ‘Mode 1’ in the Initial Set-Up Menu, you must do the following hardware set-up in order to change the transmitter:

1. Remove all the four philips screws from the back of the case.
2. Unscrew a hex screw to remove the Copper Ratchet from where it is located and move it to the other side.
3. Tighten up the tension spring hex screw on the new location.
4. Loosen up the tension hex screw on the original location.
5. Re-assemble the case.

